

MECHANICAL SEALS

TYPE 210 S

LIDERING

OPERATING LIMITS

d_1	= 25 ÷ 120 mm
p	= 40 Kg/cm ²
v	= 20 m/s
t	= -15 ÷ +200°C

The operating limits depend on the PV factor

COMPONENTS

1	Rotative face
2	Stationary face
3	O-ring
3a	O-ring
3b	O-ring
4	Spring
5a	Set screw
5b	Frange
5c	Metal frame
6	Clip screws

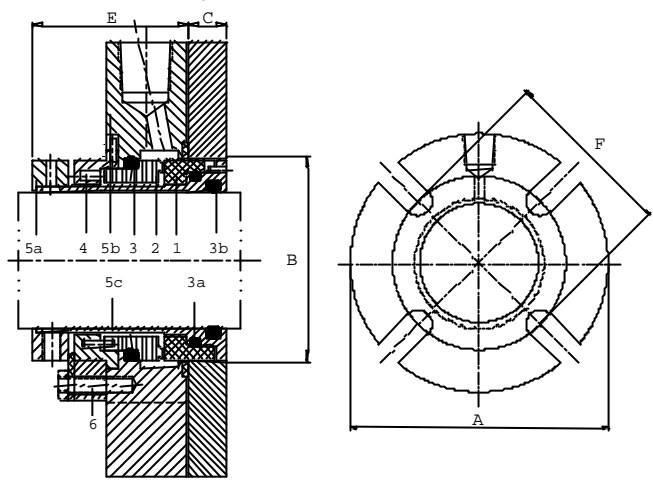

REFERENCE

MATERIALS

210 S -- QQVGG	Silicon carbide	Silicon carbide	FKM	SS AISI 316
210 S -- QQEGG	Silicon carbide	Silicon carbide	EPDM	SS AISI 316
210 S -- QBVGG	Silicon carbide	Graphite	FKM	SS AISI 316
210 S -- QBEGG	Silicon carbide	Graphite	EPDM	SS AISI 316

Available in other materials

TYPE 210 S

Cartridge simple seal, balanced, multi-spring and independent on direction of rotation.

DIMENSIONS TABLE (Measures in mm. subject to change)

Æ Shaft	A Max.	B Min.	B Max.	C Min.	E Max.	F
25	105	44	51	16	48	72
28	105	47	52	16	48	72
30	110	49	57	16	48	78
33	115	51	59	16	48	79
35	111	54	62	16	48	82
38	114	57	67	16	48	87
40	125	59	68	16	48	88
43	133	62	69	16	48	88
45	141	64	73	16	48	94
48	141	67	74	16	48	95
50	150	69	78	16	48	101
53	150	73	81	16	48	104
55	150	74	83	16	48	106
58	157	77	87	16	48	116
60	157	79	91	16	48	116
63	165	81	97	22	64	138
65	165	84	102	22	64	138
68	180	87	102	22	64	141
70	180	95	105	22	64	141
75	190	100	113	22	64	147
80	195	105	116	22	64	150
85	200	110	122	22	64	157
90	205	115	125	22	64	160
95	210	120	131	22	64	166
100	216	127	138	22	64	173
110	228	136	148	22	64	180
120	243	145	158	22	64	192



LIDERING



LIDERING, S.A.

Pg. Ferrocarrils Catalans, 106 - 108
08940 Cornellà de Llobregat BARCELONA
Domestic Sales: 902 480 440
International Sales: +34 93 480 44 22
Fax: 93 480 44 04

Cyesa,11 - 28017 MADRID
Tel: 902 480 440 Fax: 91 361 40 20

LIDERING, S.A.R.L.

Parc des Aqueducs, Lot E
Chemin du Favier RD 42
69230 Saint-Genis-Laval FRANCE
Tél: 04 72 67 02 67 Fax: 04 78 56 04 08

S.A. CONTINENTAL SEALS NEW N.V.
(LIDERING GROUP)

Ch. de Louvain 270 - Leuvensestwg
1410 Waterloo BELGIQUE-BELGIË
Tél: 02 357 06 30 Fax: 02 354 29 86

<http://www.lidering.com>