

Vee pack sets

Hallite



TECHNICAL DETAILS

METRIC

INCH

OPERATING CONDITIONS

MAXIMUM SPEED 0.5 m/sec
 TEMPERATURE RANGE -30°C + 100°C
 MAXIMUM PRESSURE 400 bar

1.5 ft/sec
 -22°F + 212°F
 6,000 p.s.i.

MAXIMUM EXTRUSION GAP

PRESSURE bar
 MAXIMUM GAP mm
 PRESSURE p.s.i.

Figures show the maximum permissible gap all on one side using minimum rod \varnothing and maximum clearance \varnothing .

100	160	250	400
0.45	0.4	0.3	0.2
1500	2400	3750	6000

SURFACE ROUGHNESS

DYNAMIC SEALING FACE $\varnothing d_1$
 STATIC SEALING FACE $\varnothing D_1$
 STATIC HOUSING FACES L_1

μmRa	μmRt	$\mu\text{in CLA}$	μinRMS
0.1 ↔ 0.4	4 max	4 ↔ 16	5 ↔ 18
1.6 max	10 max	63 max	70 max
3.2 max	16 max	125 max	140 max

CHAMFERS & RADII

GROOVE SECTION S mm
 MIN CHAMFER C mm
 MAX FILLET RAD r_2 mm

7.5	10.0	12.5	15.0
4.0	5.0	6.5	7.5
0.4	1.2	1.6	1.6

TOLERANCES

$\varnothing d_1$	$\varnothing D_1$	L_1 mm
f9	H11	+0.2 -0

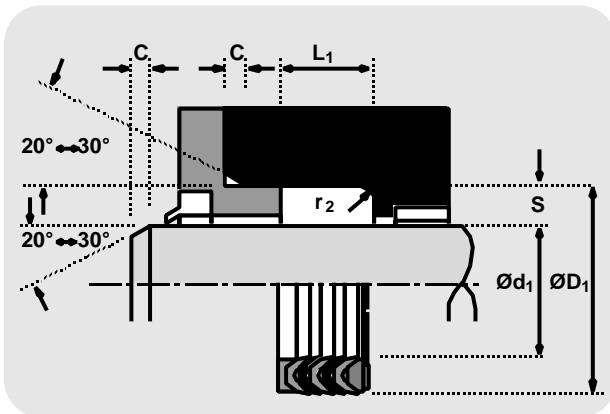

FEATURES

- PRECISION MOULDED VEE RINGS
- PRESSURE DISTRIBUTION ADAPTORS
- RELIABLE SEALING

DESIGN

The Hallite 11 is a vee pack rod seal for medium duty applications offering excellent performance and long life even under difficult operating conditions such as pressure surges, vibration and some misalignment. The seal consists of a male and female adaptor and 5 vee rings. The male adaptor is usually manufactured from polyacetal but some of the larger sizes use rubberised fabric. It has grooves across one face to ensure equal pressure to the sealing edges of the vee ring.

All sizes have three vee rings manufactured from rubberised fabric because this has strength and durability and permits an oil film to lubricate the other parts of the seal. Two rubber vee rings are supplied between the rubberised fabric vee rings (up to and including 140mm diameter) to aid low pressure sealing.

The female adaptor uses a hard rubberised fabric to support the vee rings and protect them from extrusion damage. At high pressure the lips of the adaptor acts as a secondary seal.

The proportions of the range have been determined to give a satisfactory performance when used with the recommended operating conditions.

Vee pack sets

Hallite

11

metric

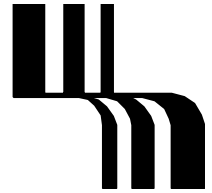
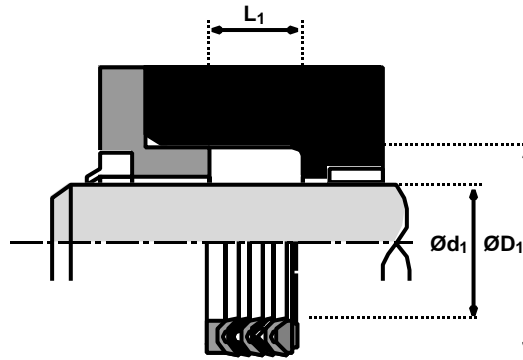

Ød ₁	TOL f9	ØD ₁	TOL H11	L ₁ +0.2-0	PART No.
20	-0.020 -0.072	30	+0.13 +0.00	18.50	4201750
25	-0.020 -0.072	37	+0.16 +0.00	22.50	4198950
28	-0.020 -0.072	40	+0.16 +0.00	22.50	4202050
30	-0.020 -0.072	42	+0.16 +0.00	22.50	4202150
32	-0.025 -0.087	44	+0.16 +0.00	22.50	4202250
35	-0.025 -0.087	47	+0.16 +0.00	22.50	4202350
36	-0.025 -0.087	48	+0.16 +0.00	22.50	4202450
40	-0.025 -0.087	52	+0.19 +0.00	22.50	4202550
42	-0.025 -0.087	54	+0.19 +0.00	22.50	4202650
45	-0.025 -0.087	60	+0.19 +0.00	22.50	4202750
50	-0.025 -0.087	65	+0.19 +0.00	22.50	4199050
55	-0.030 -0.104	70	+0.19 +0.00	22.50	4202950
56	-0.030 -0.104	71	+0.19 +0.00	22.50	4203050
60	-0.030 -0.104	75	+0.19 +0.00	22.50	4203150
63	-0.030 -0.104	78	+0.19 +0.00	22.50	4203250

Ød ₁	TOL f9	ØD ₁	TOL H11	L ₁ +0.2-0	PART No.
65	-0.030 -0.104	80	+0.19 +0.00	22.50	4203350
70	-0.030 -0.104	85	+0.22 +0.00	22.50	4203450
75	-0.030 -0.104	90	+0.22 +0.00	22.50	4203550
80	-0.030 -0.104	95	+0.22 +0.00	22.50	4203650
85	-0.036 -0.123	100	+0.22 +0.00	22.50	4203750
90	-0.036 -0.123	105	+0.22 +0.00	22.50	4203850
100	-0.036 -0.123	115	+0.22 +0.00	30.00	4203950
110	-0.036 -0.123	125	+0.25 +0.00	30.00	4204050
125	-0.043 -0.143	140	+0.25 +0.00	34.00	4204250
140	-0.043 -0.143	155	+0.25 +0.00	34.00	4199250
150	-0.043 -0.143	170	+0.25 +0.00	40.00	2196650
160	-0.043 -0.143	180	+0.25 +0.00	40.00	2196750
180	-0.043 -0.143	200	+0.29 +0.00	40.00	2196850
200	-0.050 -0.165	220	+0.29 +0.00	40.00	2196950