

Vee pack sets

Hallite



12

TECHNICAL DETAILS		METRIC	INCH	
OPERATING CONDITIONS				
MAXIMUM SPEED	0.5 m/sec	1.5 ft/sec		
TEMPERATURE RANGE	-30°C + 100°C	-22°F + 212°F		
MAXIMUM PRESSURE	400 bar	6,000 p.s.i.		
MAXIMUM EXTRUSION GAP				
PRESSURE bar	100	160	250	400
MAXIMUM GAP mm	0.45	0.4	0.3	0.2
PRESSURE p.s.i.	1500	2400	3750	6000
SURFACE ROUGHNESS				
DYNAMIC SEALING FACE $\varnothing d_1$	$0.1 \leftrightarrow 0.4$	4 max	$4 \leftrightarrow 16$	$5 \leftrightarrow 18$
STATIC SEALING FACE $\varnothing D_1$	1.6 max	10 max	63 max	70 max
STATIC HOUSING FACES L_1	3.2 max	16 max	125 max	140 max
CHAMFERS & RADII				
GROOVE SECTION S mm	7.5	10.0		
MIN CHAMFER C mm	4.0	5.0		
MAX FILLET RAD r_2 mm	0.8	1.2		
TOLERANCES				
$\varnothing d_1$	$\varnothing D_1$	L_1 mm		
f9	H11	+0.2 -0		

Figures show the maximum permissible gap all on one side using minimum rod \varnothing and maximum clearance \varnothing .

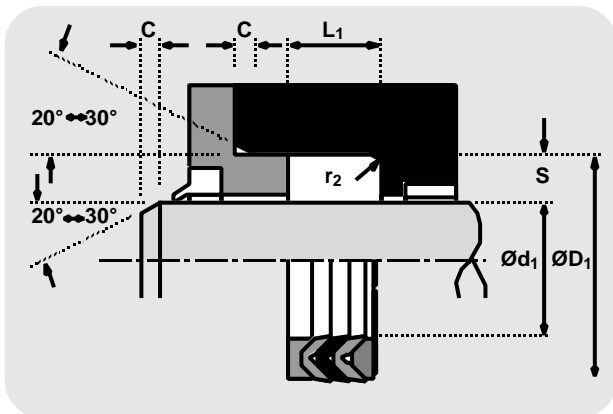

FEATURES

- PRECISION MOULDED VEE RINGS
- PRESSURE DISTRIBUTION ADAPTORS
- RELIABLE SEALING

DESIGN

The Hallite 12 is a vee pack rod seal for medium duty applications offering excellent performance and long life even under difficult operating conditions such as pressure surges, vibration and some misalignment. The seal consists of a male and female adaptor and 3 vee rings. The male adaptor is usually manufactured from polyacetal but some of the larger sizes use rubberised fabric. It has grooves across one face to ensure equal pressure to the sealing edges of the vee ring.

All the sizes have two vee rings manufactured from rubberised fabric because this has strength and durability and permits an oil film to lubricate the other parts of the seal. A rubber vee ring is supplied between the rubberised fabric vee rings (up to and including 140mm diameter) to aid low pressure sealing.

The female adaptor uses a hard rubberised fabric to support the vee rings and protect them from extrusion damage. At high pressures the lips of the adaptor act as a secondary seal.

The proportions of the range have been determined to give a satisfactory performance when used with the recommended operating conditions.

Vee pack sets

Hallite

12

metric

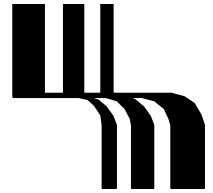
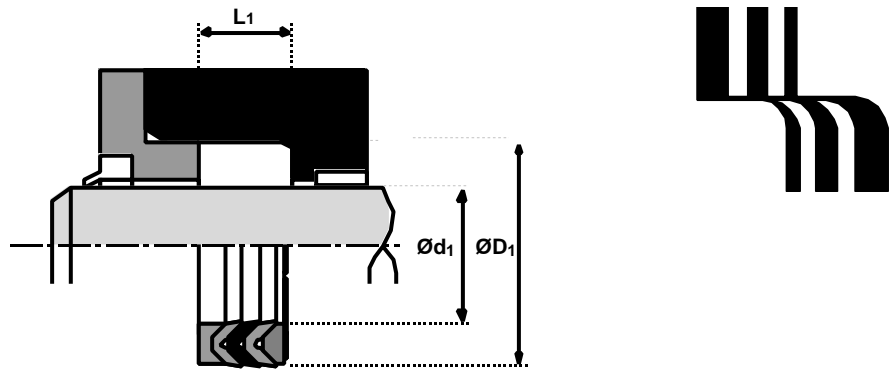

Ød ₁	TOL f9	ØD ₁	TOL H11	L ₁ +0.2-0	PART No.	Ød ₁	TOL f9	ØD ₁	TOL H11	L ₁ +0.2-0	PART No.
20	-0.020 -0.072	30	+0.13 +0.00	13.50	4201730	65	-0.030 -0.104	80	+0.19 +0.00	16.50	4203330
25	-0.020 -0.072	37	+0.16 +0.00	16.50	4198930	70	-0.030 -0.104	85	+0.22 +0.00	16.50	4203430
28	-0.020 -0.072	40	+0.16 +0.00	16.50	4202030	75	-0.030 -0.104	90	+0.22 +0.00	16.50	4203530
30	-0.020 -0.072	42	+0.16 +0.00	16.50	4202130	80	-0.030 -0.104	95	+0.22 +0.00	16.50	4203630
32	-0.025 -0.087	44	+0.16 +0.00	16.50	4202230	85	-0.036 -0.123	100	+0.22 +0.00	16.50	4203730
35	-0.025 -0.087	47	+0.16 +0.00	16.50	4202330	90	-0.036 -0.123	105	+0.22 +0.00	16.50	4203830
36	-0.025 -0.087	48	+0.16 +0.00	16.50	4202430	100	-0.036 -0.123	115	+0.22 +0.00	22.00	4203930
40	-0.025 -0.087	52	+0.019 +0.00	16.50	4202530	110	-0.036 -0.123	125	+0.25 +0.00	22.00	4204030
42	-0.025 -0.087	54	+0.19 +0.00	16.50	4202630	125	-0.043 -0.143	140	+0.25 +0.00	26.00	4204230
45	-0.025 -0.087	60	+0.19 +0.00	16.50	4202730	140	-0.043 -0.143	155	+0.25 +0.00	26.00	4199230
50	-0.025 -0.087	65	+0.19 +0.00	16.50	4199030	150	-0.043 -0.143	170	+0.25 +0.00	30.00	2196630
55	-0.030 -0.104	70	+0.19 +0.00	16.50	4202930	160	-0.043 -0.143	180	+0.25 +0.00	30.00	2196730
56	-0.030 -0.104	71	+0.19 +0.00	16.50	4203030	180	-0.043 -0.143	200	+0.29 +0.00	30.00	2196830
60	-0.030 -0.104	75	+0.19 +0.00	16.50	4203130	200	-0.050 -0.165	220	+0.29 +0.00	30.00	2196930
63	-0.030 -0.104	78	+0.19 +0.00	16.50	4203230						