

Rod buffer seals

Hallite



653

TECHNICAL DETAILS		METRIC	INCH			
OPERATING CONDITIONS						
MAXIMUM SPEED		1.0 m/sec	3.0 ft/sec			
TEMPERATURE RANGE		-45°C + 110°C	-50°F + 230°F			
MAXIMUM PRESSURE		700 bar	10,000 p.s.i.			
MAXIMUM EXTRUSION GAP						
PRESSURE bar		160	250	400	500	700
MAXIMUM GAP (S ≤ 6) mm		0.6	0.5	0.4	0.3	0.2
MAXIMUM GAP (S > 6) mm		1.0	0.8	0.6	0.4	0.25
PRESSURE p.s.i.		2400	3750	6000	7500	10,000
MAXIMUM GAP (S ≤ 0.250) in		0.024	0.020	0.016	0.012	0.008
MAXIMUM GAP (S > 0.250) in		0.040	0.032	0.024	0.016	0.010
SURFACE ROUGHNESS						
DYNAMIC SEALING FACE Ød ₁		0.1 ↔ 0.4	4 max	µinCLA	4 ↔ 16	
STATIC SEALING FACE ØD ₁		1.6 max	10 max	µinRMS	5 ↔ 18	
STATIC HOUSING FACES L ₁		3.2 max	16 max		63 max	
					140 max	
CHAMFERS & RADII						
GROOVE SECTION S mm		3.75	5.50	7.75		
MIN CHAMFER C mm		3.00	3.50	5.00		
MAX FILLET RAD r ₁ mm		0.50	0.70	1.20		
GROOVE SECTION S in		0.150	0.215	0.306		
MIN CHAMFER C in		0.093	0.125	0.156		
MAX FILLET RAD r ₁ in		0.020	0.028	0.047		
TOLERANCES						
		Ød ₁	ØD ₁	L ₁		
	mm	f9	H11	+0.25 -0		
	in	f9	Js11	+0.010 -0		

Figures show the maximum permissible gap all on one side using minimum rod Ø and maximum clearance Ø.

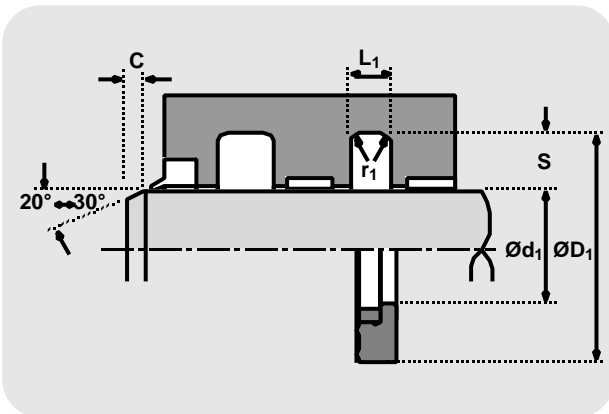

DESIGN

The Hallite 653 is a buffer seal developed to work in conjunction with high performance rod seals, such as the Hallite 605 and 621. It is also interchangeable with common PTFE buffer seal housings.

The seal, which is manufactured in Hythane 181, is designed to provide a valve action to prevent excessive pressure build up in the cavity between the buffer seal and the rod seal. An acetal anti-extrusion ring is fitted to provide maximum extrusion resistance against shock pressure loads.

The Hallite 653 is a patented product :

European patent no. 0427554Bl.

U.S.A. patent no. 5088747.

FEATURES

- PREVENTS INTER-SEAL PRESSURE BUILD UP
- INTERCHANGEABLE WITH COMMON PTFE BUFFER SEAL HOUSINGS
- EASY INSTALLATION
- LONG LIFE
- EXCELLENT TEMPERATURE RANGE

Rod buffer seals

Hallite 653

metric

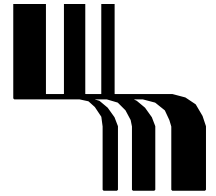
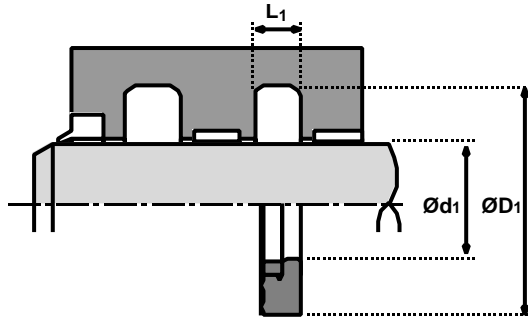

$\varnothing d_1$	TOL f9	$\varnothing D_1$	TOL H11	L_1 +0.25 -0	PART No.
45.0	-0.025 -0.087	56.0	+0.19 +0.00	4.2	4575510
50.0	-0.025 -0.087	65.5	+0.19 +0.00	6.3	4403210
55.0	-0.030 -0.104	70.5	+0.19 +0.00	6.3	4403310

$\varnothing d_1$	TOL f9	$\varnothing D_1$	TOL H11	L_1 +0.25 -0	PART No.
60.0	-0.030 -0.104	75.5	+0.19 +0.00	6.3	4403410
90.0	-0.036 -0.123	105.5	+0.22 +0.00	6.3	4523710
215.0	-0.050 -0.165	236.0	+0.29 +0.00	8.1	4705710

inch

$\varnothing d_1$	TOL f9	$\varnothing D_1$	TOL Js11	L_1 +0.010 -0	PART No.
2.000	-0.0012 -0.0041	2.424	+0.004 -0.004	0.166	4521310
2.500	-0.0012 -0.0041	2.924	+0.004 -0.004	0.166	4514610
2.750	-0.0012 -0.0041	3.174	+0.004 -0.004	0.166	4533510
3.000	-0.0012 -0.0041	3.616	+0.004 -0.004	0.247	4515910

$\varnothing d_1$	TOL f9	$\varnothing D_1$	TOL Js11	L_1 +0.010 -0	PART No.
3.500	-0.0014 -0.0048	4.116	+0.004 -0.004	0.247	4514810
4.000	-0.0014 -0.0048	4.616	+0.004 -0.004	0.247	4524610
7.000	-0.0016 -0.0056	7.610	+0.006 -0.006	0.247	4588310