

Piston seals

Hallite

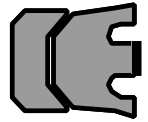

TECHNICAL DETAILS		METRIC	INCH			
OPERATING CONDITIONS						
MAXIMUM SPEED		0.8 m/sec	2.4 ft/sec			
TEMPERATURE RANGE		-30°C + 100°C	-22°F + 212°F			
MAXIMUM PRESSURE		600 bar	9000 p.s.i.			
MAXIMUM EXTRUSION GAP						
PRESSURE bar		160	250	400	600	
MAXIMUM GAP mm		0.35	0.3	0.2	0.1	
PRESSURE p.s.i.		2400	3750	6000	9000	
SURFACE ROUGHNESS						
DYNAMIC SEALING FACE $\varnothing d_1$		0.1 ↔ 0.4	4 max	4 ↔ 16	5 ↔ 18	
STATIC SEALING FACE $\varnothing d_1$		1.6 max	10 max	63 max	70 max	
STATIC HOUSING FACES L_1		3.2 max	16 max	125 max	140 max	
CHAMFERS & RADII						
GROOVE SECTION S mm		5.0	7.5	10.0	12.5	15.0
MIN CHAMFER C mm		2.5	4.0	5.0	6.5	7.5
MAX FILLET RAD r_2 mm		0.8	0.8	0.8	1.2	1.6
TOLERANCES						
		$\varnothing D_1$	$\varnothing d_1$	$\varnothing d_3$	L_1	
	mm	H9	h11	+0 -0.3	+0.3 -0	

Figures show the maximum permissible gap all on one side using the minimum clearance \varnothing and maximum bore \varnothing

μmRa	μmRt	μinCLA	μinRMS
0.1 ↔ 0.4	4 max	4 ↔ 16	5 ↔ 18
1.6 max	10 max	63 max	70 max
3.2 max	16 max	125 max	140 max

5.0	7.5	10.0	12.5	15.0
2.5	4.0	5.0	6.5	7.5
0.8	0.8	0.8	1.2	1.6

$\varnothing D_1$	$\varnothing d_1$	$\varnothing d_3$	L_1
H9	h11	+0 -0.3	+0.3 -0

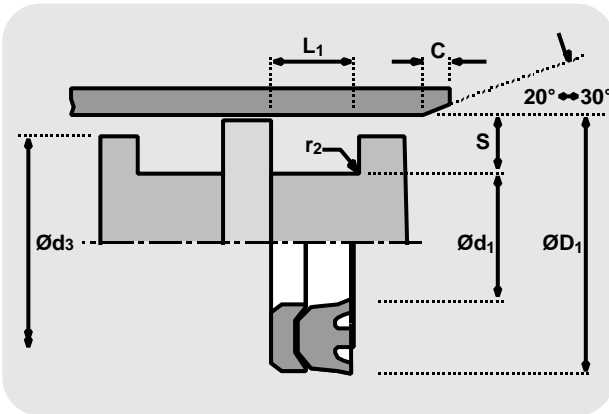

DESIGN

The Hallite 52 is a two piece piston seal for heavy duty applications which, when installed in pairs, provides an excellent double-acting piston design. It is suitable for difficult operating conditions such as pressure surging, vibration or some misalignment.

Both parts are manufactured from rubberised fabric which gives strength and durability and retains lubrication to keep friction low and reduce wear.

By extending the centre of the seal past the sealing edges, they are protected from damage should inter-seal pressure force the seal against the housing wall. Grooves across the protruding face allow pressure to reach both sealing edges.

The support ring is manufactured from a hard rubberised fabric to protect the seal from extrusion damage. The 'U' shape of the ring provides a secondary seal as pressure deforms the lips to increase the sealing area.

NB: Part numbers suffixed by "‡" indicate housing sizes to meet ISO 5597.

FEATURES

- EFFECTIVE SEAL FOR EXTREME APPLICATIONS
- PRECISION MOULDED VEE PACKS
- HIGH LOAD CAPABILITY
- PRESSURE ACTIVATING GROOVES

Piston seals

Hallite

52

metric

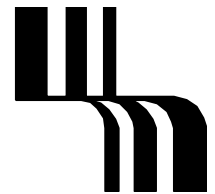
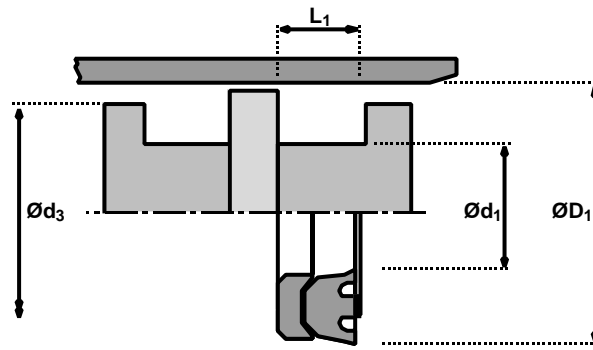

ØD ₁	TOL H9	Ød ₁	TOL h11	Ød ₃ Tol +0 -0.3	L ₁ +0.3 -0	PART No.
25	+0.05 +0.00	15	+0.00 -0.11	24.0	6.30	6619810‡
32	+0.06 +0.00	20	+0.00 -0.13	31.0	7.80	1791610
32	+0.06 +0.00	22	+0.00 -0.13	31.0	6.30	6619910‡
40	+0.06 +0.00	25	+0.00 -0.13	39.0	10.00	2149810
40	+0.06 +0.00	30	+0.00 -0.13	39.0	6.30	6620010‡
45	+0.06 +0.00	30	+0.00 -0.13	44.0	10.00	2150010
50	+0.06 +0.00	35	+0.00 -0.16	49.0	9.50	2150210‡
55	+0.07 +0.00	40	+0.00 -0.16	54.0	10.00	2150410
60	+0.07 +0.00	45	+0.00 -0.16	59.0	10.00	2150610
63	+0.07 +0.00	48	+0.00 -0.16	62.0	9.50	2150810‡
70	+0.07 +0.00	50	+0.00 -0.16	68.5	13.00	2151010
80	+0.07 +0.00	60	+0.00 -0.19	78.5	12.50	2151210‡
90	+0.09 +0.00	70	+0.00 -0.19	88.5	13.00	2151410

ØD ₁	TOL H9	Ød ₁	TOL h11	Ød ₃ Tol +0 -0.3	L ₁ +0.3 -0	PART No.
100	+0.09 +0.00	80	+0.00 -0.19	98.5	12.50	2151610‡
110	+0.09 +0.00	90	+0.00 -0.22	108.5	13.00	2151810
125	+0.10 +0.00	100	+0.00 -0.22	123.5	16.00	2152010‡
140	+0.10 +0.00	115	+0.00 -0.22	138.5	16.20	2152210
160	+0.10 +0.00	130	+0.00 -0.25	158.0	19.80	2152410
160	+0.10 +0.00	135	+0.00 -0.25	158.0	16.00	6620110‡
180	+0.10 +0.00	150	+0.00 -0.25	178.0	19.80	2152610
200	+0.12 +0.00	170	+0.00 -0.25	198.0	20.00	2152810‡
225	+0.12 +0.00	195	+0.00 -0.29	223.0	19.80	2197010
250	+0.12 +0.00	220	+0.00 -0.29	248.0	20.00	2197210‡
275	+0.13 +0.00	245	+0.00 -0.29	273.0	19.80	2197410
300	+0.13 +0.00	270	+0.00 -0.32	298.0	19.80	2188310