

## Piston seals

# Hallite

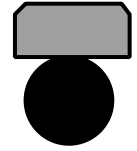

### TECHNICAL DETAILS

METRIC

INCH

#### OPERATING CONDITIONS

MAXIMUM SPEED 4.0 m/sec  
 TEMPERATURE RANGE -30°C + 100°C  
 MAXIMUM PRESSURE 350 bar

12.0 ft/sec  
 -22°F + 212°F  
 5000 p.s.i.

#### MAXIMUM EXTRUSION GAP

PRESSURE bar	100	160	250	350
MAXIMUM GAP mm	0.60	0.50	0.45	0.35
PRESSURE p.s.i.	1500	2400	3750	5250
MAXIMUM GAP in	0.024	0.020	0.018	0.014

Figures show the maximum permissible gap all on one side using the minimum clearance  $\emptyset$  and maximum bore  $\emptyset$

#### SURFACE ROUGHNESS

	$\mu\text{mRa}$	$\mu\text{mRt}$	$\mu\text{inCLA}$	$\mu\text{inRMS}$
DYNAMIC SEALING FACE $\emptyset D_1$	0.1 $\leftrightarrow$ 0.4	4 max	4 $\leftrightarrow$ 16	5 $\leftrightarrow$ 18
STATIC SEALING FACE $\emptyset d_1$	1.6 max	10 max	63 max	70 max
STATIC HOUSING FACES $L_1$	3.2 max	16 max	125 max	140 max

#### CHAMFERS & RADII

GROOVE SECTION S mm	3.75	5.50	7.75	10.50	12.25
MIN CHAMFER C mm	2.00	2.50	5.00	7.50	10.00
MAX FILLET RAD $r_1$ mm	0.40	0.80	1.20	1.60	2.00
GROOVE SECTION S in	0.147	0.216	0.305	0.413	0.483
MIN CHAMFER C in	0.093	0.125	0.156	0.187	0.305
MAX FILLET RAD $r_1$ in	0.016	0.016	0.032	0.032	0.032

#### TOLERANCES

	$\emptyset D_1$	$\emptyset d_1$	$L_1$
mm	H9	f8	+0.2 -0
in	H9	f8	+0.008 -0

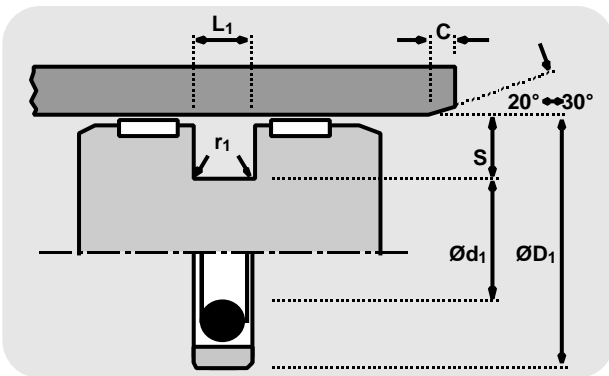

### FEATURES

- LOW STICK/SLIP
- LOW BREAKOUT & RUNNING FRICTION
- HIGH MAXIMUM SPEED
- COMPACT PISTON DESIGN
- THE SEAL RING COMPONENT CAN BE MACHINED TO ANY SIZE

### MATERIALS

Face material - O-Ring	last two digits of part number
Standard material	
15% Glass/PTFE - NBR	10
Material options:	
15% Glass/PTFE - FKM	11
Bronze/PTFE - NBR	20
Bronze/PTFE - FKM	21

### DESIGN

The Hallite 54 double acting piston seal provides the designer with a compact, low friction seal for light to medium duty hydraulic cylinders.

It comprises a PTFE ring, strengthened with additives to resist creep, which is pre-loaded by an O ring to be effective for the operating pressure range recommended. As the pressure rises the O ring deforms and compresses the PTFE ring against the tube wall increasing the sealing force and the effectiveness of the seal. As only the PTFE ring is in contact with the sliding surface, friction is very low and stick-slip movement is eliminated.

The housing width allows the designer to use a narrow width piston, but it is recommended an adequate bearing is mounted either side of the seal as shown.\*

A number of material options can be provided to extend operating conditions. Please ensure that the correct part number is specified for the material option as indicated. Technical details shown are for 15% Glass/PTFE and NBR energiser. Technical details for material options should be requested from Hallite Seals. The Hallite 54 seal is not recommended for applications where it is necessary for the pressurised cylinder to maintain the load in a set position.

\*See Hallite 87 and 506 wear ring data sheets.

**NB:** Part numbers suffixed by "‡" indicate housing sizes to meet ISO 7425-1.

Piston seals

# Hallite

## 54

metric

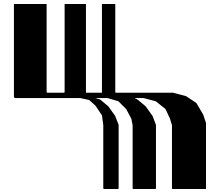
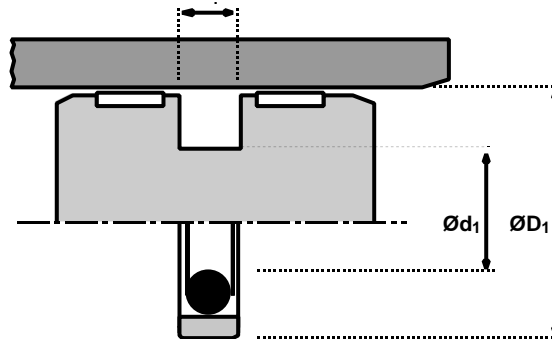

ØD <sub>1</sub>	TOL H9	Ød <sub>1</sub>	TOL f8	L <sub>1</sub> +0.2 -0	PART No.
12	+0.04 +0.00	7.1	-0.01 -0.04	2.20	66239__
15	+0.04 +0.00	7.5	-0.01 -0.04	3.20	86163__
16	+0.04 +0.00	8.5	-0.01 -0.04	3.20	66240__ ‡
20	+0.05 +0.00	12.5	-0.02 -0.04	3.20	66241__ ‡
24	+0.05 +0.00	16.5	-0.02 -0.04	3.20	66154__
25	+0.05 +0.00	17.5	-0.02 -0.04	3.20	66242__ ‡
30	+0.05 +0.00	22.5	-0.02 -0.05	3.20	65968__
32	+0.06 +0.00	24.5	-0.02 -0.05	3.20	65969__ ‡
35	+0.06 +0.00	27.5	-0.02 -0.05	3.20	65970__
38	+0.06 +0.00	30.5	-0.03 -0.06	3.20	66475__
40	+0.06 +0.00	29.0	-0.02 -0.05	4.20	65971__ ‡
42	+0.06 +0.00	31.0	-0.03 -0.06	4.20	65972__
45	+0.06 +0.00	34.0	-0.03 -0.06	4.20	65973__
50	+0.06 +0.00	39.0	-0.03 -0.06	4.20	65974__ ‡
55	+0.07 +0.00	44.0	-0.03 -0.06	4.20	65975__
60	+0.07 +0.00	49.0	-0.03 -0.06	4.20	65976__
63	+0.07 +0.00	52.0	-0.03 -0.08	4.20	66243__ ‡
65	+0.07 +0.00	54.0	-0.03 -0.08	4.20	86118__
70	+0.07 +0.00	59.0	-0.03 -0.08	4.20	65977__
75	+0.07 +0.00	64.0	-0.03 -0.08	4.20	66244__
80	+0.07 +0.00	64.5	-0.03 -0.08	6.30	65978__ ‡
90	+0.09 +0.00	74.5	-0.03 -0.08	6.30	65979__
95	+0.09 +0.00	79.5	-0.03 -0.08	6.30	86084__

ØD <sub>1</sub>	TOL H9	Ød <sub>1</sub>	TOL f8	L <sub>1</sub> +0.2 -0	PART No.
100	+0.09 +0.00	84.5	-0.04 -0.09	6.30	65980__ ‡
110	+0.09 +0.00	94.5	-0.04 -0.09	6.30	65981__
115	+0.09 +0.00	99.5	-0.04 -0.09	6.30	65982__
120	+0.09 +0.00	104.5	-0.04 -0.09	6.30	66361__
125	+0.10 +0.00	109.5	-0.04 -0.09	6.30	65983__ ‡
130	+0.10 +0.00	114.5	-0.04 -0.09	6.30	66476__
135	+0.10 +0.00	114.0	-0.04 -0.09	8.10	66477__
140	+0.10 +0.00	119.0	-0.04 -0.09	8.10	65984__
145	+0.10 +0.00	124.0	-0.04 -0.11	8.10	86080__
150	+0.10 +0.00	129.0	-0.04 -0.11	8.10	65985__
155	+0.10 +0.00	134.0	-0.04 -0.11	8.10	86177__
160	+0.10 +0.00	139.0	-0.04 -0.11	8.10	65986__ ‡
165	+0.10 +0.00	144.0	-0.04 -0.11	8.10	66491__
170	+0.10 +0.00	149.0	-0.04 -0.11	8.10	65987__
180	+0.10 +0.00	159.0	-0.04 -0.11	8.10	65988__
185	+0.12 +0.00	164.0	-0.04 -0.11	8.10	66478__
190	+0.12 +0.00	169.0	-0.04 -0.11	8.10	65989__
200	+0.12 +0.00	179.0	-0.04 -0.11	8.10	65990__ ‡
210	+0.12 +0.00	189.0	-0.05 -0.12	8.10	86146__
220	+0.12 +0.00	199.0	-0.05 -0.12	8.10	66245__
225	+0.12 +0.00	204.0	-0.05 -0.12	8.10	66246__
230	+0.12 +0.00	209.0	-0.05 -0.12	8.10	66247__
240	+0.12 +0.00	219.0	-0.05 -0.12	8.10	86154__

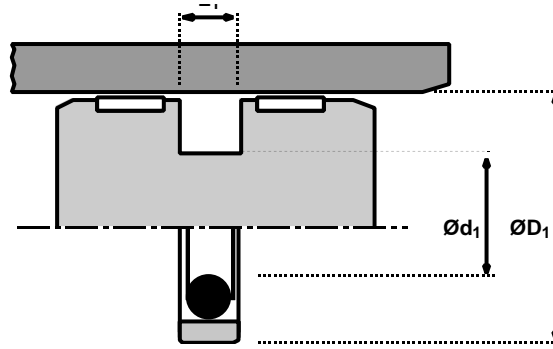
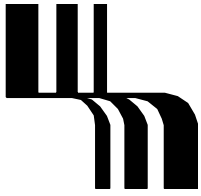

Piston seals  
**Hallite**  
**54**  
 metric

ØD <sub>1</sub>	TOL H9	Ød <sub>1</sub>	TOL f8	L <sub>1</sub> + 0.2 - 0	PART No.
250	+0.12 +0.00	229.0	-0.05 -0.12	8.10	66401__ ‡
260	+0.12 +0.00	239.0	-0.05 -0.12	8.10	66479__
280	+0.13 +0.00	259.0	-0.06 -0.14	8.10	66402__
300	+0.13 +0.00	279.0	-0.06 -0.14	8.10	66403__
310	+0.13 +0.00	289.0	-0.06 -0.14	8.10	66480__
320	+0.13 +0.00	299.0	-0.06 -0.14	8.10	86086__ ‡
330	+0.13 +0.00	305.5	-0.06 -0.14	8.10	86081__
340	+0.13 +0.00	315.5	-0.06 -0.14	8.10	66481__

ØD <sub>1</sub>	TOL H9	Ød <sub>1</sub>	TOL f8	L <sub>1</sub> + 0.2 - 0	PART No.
350	+0.13 +0.00	325.5	-0.06 -0.14	8.10	86155__
360	+0.13 +0.00	335.5	-0.06 -0.14	8.10	86218__
370	+0.13 +0.00	345.5	-0.06 -0.14	8.10	86219__
380	+0.13 +0.00	355.5	-0.06 -0.14	8.10	86220__
390	+0.13 +0.00	365.5	-0.06 -0.14	8.10	86221__
400	+0.13 +0.00	375.5	-0.06 -0.14	8.10	66482__ ‡

Piston seals

# Hallite 54

inch

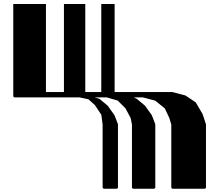
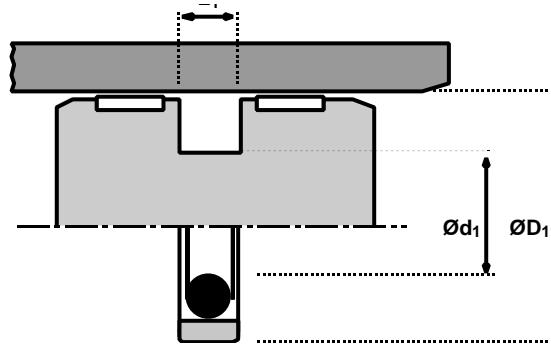

$\varnothing D_1$	TOL H9	$\varnothing d_1$	TOL f8	$L_1$ + 0.008 - 0	PART No.	$\varnothing D_1$	TOL H9	$\varnothing d_1$	TOL f8	$L_1$ + 0.008 - 0	PART No.
1.000	+0.002 +0.000	0.704	-0.0008 -0.0020	0.125	66248_ _	4.000	+0.003 +0.000	3.390	-0.0014 -0.0036	0.250	66255_ _
1.500	+0.002 +0.000	1.204	-0.0010 -0.0026	0.125	66249_ _	4.500	+0.003 +0.000	3.890	-0.0014 -0.0036	0.250	66256_ _
2.000	+0.003 +0.000	1.568	-0.0012 -0.0030	0.165	66250_ _	5.000	+0.004 +0.000	4.390	-0.0016 -0.0041	0.250	66257_ _
2.500	+0.003 +0.000	2.068	-0.0012 -0.0030	0.165	66251_ _	6.000	+0.004 +0.000	5.174	-0.0016 -0.0041	0.320	66258_ _
3.000	+0.003 +0.000	2.568	-0.0012 -0.0030	0.165	66252_ _	7.000	+0.004 +0.000	6.174	-0.0016 -0.0041	0.320	66259_ _
3.250	+0.003 +0.000	2.640	-0.0014 -0.0036	0.250	66253_ _	8.000	+0.004 +0.000	7.174	-0.0020 -0.0048	0.320	66260_ _
3.500	+0.003 +0.000	2.890	-0.0014 -0.0036	0.250	66254_ _						