

Piston seals

Hallite

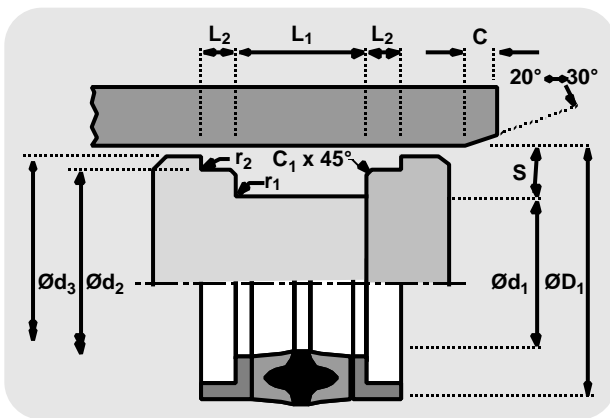

TECHNICAL DETAILS		METRIC	INCH			
OPERATING CONDITIONS						
MAXIMUM SPEED	0.5 m/sec	1.5 ft/sec				
TEMPERATURE RANGE	-30°C + 100°C	-22°F + 212°F				
MAXIMUM PRESSURE	700 bar	10,000 p.s.i.				
SURFACE ROUGHNESS						
DYNAMIC SEALING FACE $\varnothing D_1$	μmRa 0.1 ↔ 0.4	μmRt 4 max	μinCLA 4 ↔ 16	μinRMS 5 ↔ 18		
STATIC SEALING FACE $\varnothing d_1$ $\varnothing d_2$	1.6 max	10 max	63 max	70 max		
STATIC HOUSING FACES $\varnothing d_3$ L_1 L_2	3.2 max	16 max	125 max	140 max		
CHAMFERS & RADII						
GROOVE SECTION S mm	5.0	7.5	10.0	12.5	15.0	
MIN CHAMFER C mm	2.5	4.0	5.0	6.5	7.5	
MIN CHAMFER C_1 mm	1.0	1.0	1.0	1.5	1.5	
MAX FILLET RAD r_1 mm	0.2	0.2	0.2	0.4	0.4	
MAX FILLET RAD r_2 mm	0.2	0.2	0.2	0.4	0.4	
GROOVE SECTION S in	0.187	0.250	0.312	0.375	0.500	0.625
MIN CHAMFER C in	0.093	0.125	0.156	0.187	0.217	0.250
MIN CHAMFER C_1 in	0.032	0.032	0.032	0.062	0.062	0.062
MAX FILLET RAD r_1 in	0.008	0.008	0.008	0.008	0.016	0.016
MAX FILLET RAD r_2 in	0.008	0.008	0.008	0.008	0.016	0.016
TOLERANCES						
	$\varnothing D_1$	$\varnothing d_1$	$\varnothing d_2$	$\varnothing d_3$	L_1	L_2
mm	H11	js11	h9	js11	+0.25 -0	0 -0.15
in	H11	js11	h9	js11	+0.035 +0.025	0 -0.005



FEATURES

- WELL PROVEN DESIGN
- TOLERANT TO CONTAMINATION
- HIGH PRESSURE CAPABILITY

DESIGN

The Hallite 85 double acting piston seal combines the Hallite 56 seal with bearing rings to give a very robust heavy duty seal assembly for split pistons. It enables the designer to use larger clearances and, with the integral bearing rings, to restrict the piston length.

The assembly comprises a seal and two L shaped bearings. The centre of the seal is rubber which is bonded to two 'U' section bases of rubberised fabric, and is compressed by the housing to obtain an effective low pressure seal. When the pressure increases the rubber energises the 'U' section and deforms it to the housing, increasing the sealing area and improving the seal.

Rubberised fabric is used to protect the rubber, because it has strength and durability which combines with its ability to retain lubricant to help keep friction low and reduce wear.

Supporting the seal at either end is a polyacetal bearing proportioned to react to the pressure on the seal to prevent extrusion damage, and support the piston and its side load.

Piston seals

Hallite 58

metric

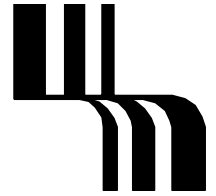
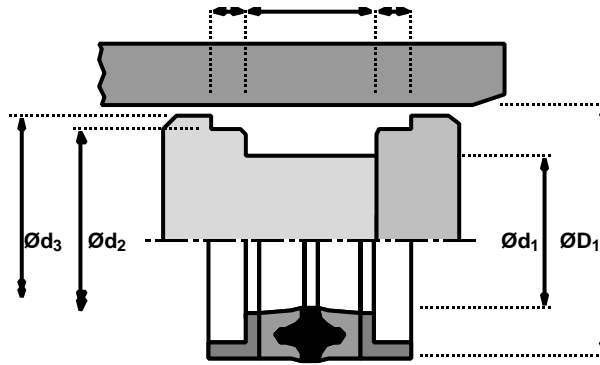

ØD1	TOL H11	Ød1	TOL js11	Ød2	TOL h9	Ød3	TOL js11	L1 + 0.25 - 0	L2 0 - 0.15	PART No.
40	+0.16 +0.00	25	+0.07 -0.07	34.85	+0.000 -0.062	39.0	+0.08 -0.08	24.0	6.00	0472850
50	+0.16 +0.00	35	+0.08 -0.08	44.85	+0.000 -0.062	48.5	+0.08 -0.08	24.0	6.00	0474650
55	+0.19 +0.00	40	+0.08 -0.08	49.85	+0.000 -0.062	53.5	+0.10 -0.10	24.0	6.00	0475050
60	+0.19 +0.00	40	+0.08 -0.08	53.85	+0.000 -0.074	58.5	+0.10 -0.10	31.0	7.00	0282050
63	+0.19 +0.00	43	+0.08 -0.08	56.85	+0.000 -0.074	61.5	+0.10 -0.10	31.0	7.00	0646750
63	+0.19 +0.00	48	+0.08 -0.08	57.85	+0.000 -0.074	61.5	+0.10 -0.10	24.0	6.00	0205250
65	+0.19 +0.00	50	+0.08 -0.08	59.85	+0.000 -0.074	63.5	+0.10 -0.10	24.0	6.00	0383850
70	+0.19 +0.00	50	+0.08 -0.08	63.85	+0.000 -0.074	68.0	+0.10 -0.10	31.0	7.00	0294650
75	+0.19 +0.00	55	+0.10 -0.10	68.85	+0.000 -0.074	73.0	+0.10 -0.10	31.0	7.00	0818650
80	+0.19 +0.00	60	+0.10 -0.10	73.85	+0.000 -0.074	78.0	+0.10 -0.10	31.0	7.00	0294950
85	+0.19 +0.00	65	+0.10 -0.10	78.85	+0.000 -0.074	83.0	+0.11 -0.11	31.0	7.00	0388650
90	+0.22 +0.00	70	+0.10 -0.10	83.85	+0.000 -0.087	88.0	+0.11 -0.11	31.0	7.00	0296050
95	+0.22 +0.00	75	+0.10 -0.10	88.85	+0.000 -0.087	93.0	+0.11 -0.11	31.0	7.00	0412750
100	+0.22 +0.00	75	+0.10 -0.10	93.24	+0.000 -0.087	98.0	+0.11 -0.11	22.0	6.45	0034950
100	+0.22 +0.00	75	+0.10 -0.10	93.85	+0.000 -0.087	98.0	+0.11 -0.11	26.0	9.50	0891650
100	+0.22 +0.00	80	+0.10 -0.10	93.85	+0.000 -0.087	98.0	+0.11 -0.11	31.0	7.00	0295150
105	+0.22 +0.00	80	+0.11 -0.11	98.85	+0.000 -0.087	103.0	+0.11 -0.11	38.0	9.50	0413150
110	+0.22 +0.00	85	+0.11 -0.11	103.50	+0.000 -0.087	108.0	+0.11 -0.11	22.0	6.45	1188250
110	+0.22 +0.00	85	+0.11 -0.11	103.50	+0.000 -0.087	108.0	+0.11 -0.11	25.0	6.45	0820650
110	+0.22 +0.00	90	+0.11 -0.11	103.85	+0.000 -0.087	108.0	+0.11 -0.11	31.0	7.00	0712450
115	+0.22 +0.00	95	+0.11 -0.11	108.85	+0.000 -0.087	113.0	+0.11 -0.11	31.0	7.00	0796450
120	+0.22 +0.00	100	+0.11 -0.11	113.85	+0.000 -0.087	118.0	+0.11 -0.11	31.0	7.00	0296150
125	+0.25 +0.00	100	+0.11 -0.11	118.50	+0.000 -0.087	123.0	+0.13 -0.13	25.0	6.45	1007450

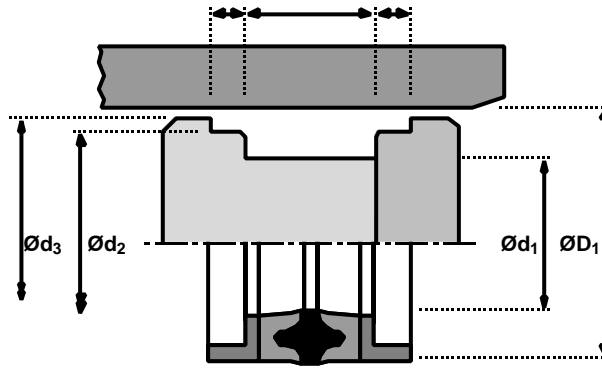
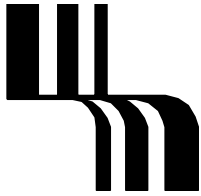

Piston seals

Hallite

58

metric

ØD ₁	TOL H11	Ød ₁	TOL js11	Ød ₂	TOL h9	Ød ₃	TOL js11	L ₁ + 0.25 - 0	L ₂ 0 - 0.15	PART No.
125	+0.25 +0.00	100	+0.11 -0.11	118.85	+0.000 -0.087	123.0	+0.13 -0.13	38.0	9.50	0418650
130	+0.25 +0.00	104	+0.11 -0.11	123.85	+0.000 -0.100	128.0	+0.13 -0.13	38.0	9.50	0244350
130	+0.25 +0.00	105	+0.11 -0.11	123.50	+0.000 -0.100	128.0	+0.13 -0.13	25.0	6.45	0044850
135	+0.25 +0.00	110	+0.11 -0.11	128.35	+0.000 -0.100	133.0	+0.13 -0.13	38.0	9.50	0304350
140	+0.25 +0.00	115	+0.11 -0.11	133.50	+0.000 -0.100	138.0	+0.13 -0.13	25.0	6.45	1008450
140	+0.25 +0.00	120	+0.11 -0.11	133.85	+0.000 -0.100	138.0	+0.13 -0.13	31.0	7.00	0250550
145	+0.25 +0.00	125	+0.11 -0.11	138.85	+0.000 -0.100	143.0	+0.13 -0.13	31.0	7.00	0640150
150	+0.25 +0.00	120	+0.11 -0.11	143.85	+0.000 -0.100	148.0	+0.13 -0.13	44.0	9.50	1289550
160	+0.25 +0.00	130	+0.13 -0.13	153.50	+0.000 -0.100	158.0	+0.13 -0.13	25.0	6.45	1008250
160	+0.25 +0.00	135	+0.13 -0.13	153.85	+0.000 -0.100	158.0	+0.13 -0.13	38.0	9.50	0080450
160	+0.25 +0.00	140	+0.13 -0.13	153.85	+0.000 -0.100	158.0	+0.13 -0.13	31.0	7.00	0304650
170	+0.25 +0.00	140	+0.13 -0.13	162.54	+0.000 -0.100	168.0	+0.13 -0.13	25.0	6.45	1222250
170	+0.25 +0.00	150	+0.13 -0.13	163.85	+0.000 -0.100	168.0	+0.13 -0.13	31.0	7.00	0303350
180	+0.25 +0.00	150	+0.13 -0.13	173.00	+0.000 -0.100	178.0	+0.13 -0.13	35.0	6.45	0679850
180	+0.25 +0.00	160	+0.13 -0.13	173.85	+0.000 -0.100	178.0	+0.13 -0.13	31.0	7.00	1283150
190	+0.29 +0.00	160	+0.13 -0.13	183.85	+0.000 -0.115	188.0	+0.15 -0.15	44.0	9.50	0838450
200	+0.29 +0.00	170	+0.13 -0.13	193.85	+0.000 -0.115	198.0	+0.15 -0.15	44.0	12.00	0087150
200	+0.29 +0.00	175	+0.13 -0.13	193.85	+0.000 -0.115	198.0	+0.15 -0.15	38.0	9.5	0838850
210	+0.29 +0.00	180	+0.13 -0.13	203.13	+0.000 -0.115	208.0	+0.15 -0.15	31.7	6.45	1198450
220	+0.29 +0.00	200	+0.15 -0.15	213.85	+0.000 -0.115	218.0	+0.15 -0.15	31.0	7.0	1056450
250	+0.29 +0.00	220	+0.15 -0.15	243.85	+0.000 -0.115	248.0	+0.15 -0.15	44.0	12.0	1056350
280	+0.32 +0.00	250	+0.15 -0.15	273.85	+0.000 -0.130	278.0	+0.16 -0.16	44.0	12.0	1055550

Piston seals

Hallite 58

inch

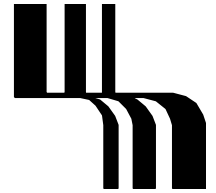
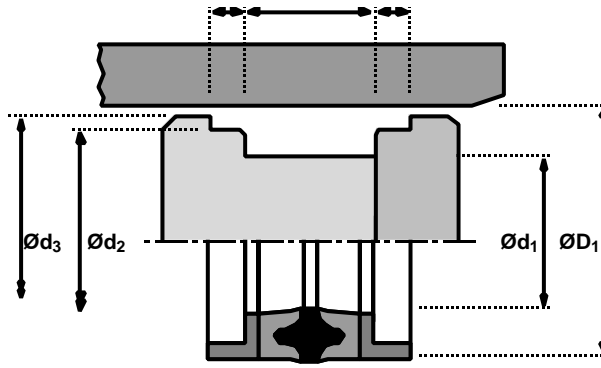

ØD ₁	TOL H11	Ød ₁	TOL js11	Ød ₂	TOL h9	Ød ₃	TOL js11	L ₁ + 0.035 + 0.025	L ₂ 0 - 0.005	PART No.
1.000	+0.005 +0.000	0.500	+0.002 -0.002	0.864	+0.000 -0.002	0.960	+0.003 -0.003	0.625	0.188	0723850
1.000	+0.005 +0.000	0.625	+0.002 -0.002	0.868	+0.000 -0.002	0.968	+0.003 -0.003	0.594	0.187	1247650
1.125	+0.006 +0.000	0.625	+0.002 -0.002	0.990	+0.000 -0.002	1.093	+0.003 -0.003	0.750	0.250	0855050
1.250	+0.006 +0.000	0.750	+0.003 -0.003	1.118	+0.000 -0.002	1.218	+0.003 -0.003	0.750	0.250	0403750
1.375	+0.006 +0.000	0.875	+0.003 -0.003	1.234	+0.000 -0.002	1.343	+0.003 -0.003	0.625	0.254	6503550
1.375	+0.006 +0.000	0.875	+0.003 -0.003	1.241	+0.000 -0.002	1.343	+0.003 -0.003	0.750	0.250	0401350
1.500	+0.006 +0.000	1.000	+0.003 -0.003	1.362	+0.000 -0.002	1.460	+0.003 -0.003	0.625	0.188	6504850
1.500	+0.006 +0.000	1.000	+0.003 -0.003	1.362	+0.000 -0.002	1.460	+0.003 -0.003	0.625	0.254	1441150
1.500	+0.006 +0.000	1.000	+0.003 -0.003	1.371	+0.000 -0.002	1.468	+0.003 -0.003	0.750	0.250	0422450
1.625	+0.006 +0.000	1.000	+0.003 -0.003	1.428	+0.000 -0.002	1.562	+0.003 -0.003	0.937	0.250	0540650
1.750	+0.006 +0.000	1.125	+0.003 -0.003	1.555	+0.000 -0.002	1.687	+0.003 -0.003	0.937	0.250	0778250
1.750	+0.006 +0.000	1.125	+0.003 -0.003	1.572	+0.000 -0.002	1.710	+0.003 -0.003	0.750	0.254	6504450
1.875	+0.006 +0.000	1.250	+0.003 -0.003	1.678	+0.000 -0.002	1.812	+0.003 -0.003	0.937	0.250	0404150
2.000	+0.007 +0.000	1.375	+0.003 -0.003	1.805	+0.000 -0.002	1.937	+0.004 -0.004	0.937	0.250	0778450
2.000	+0.007 +0.000	1.375	+0.003 -0.003	1.822	+0.000 -0.002	1.962	+0.004 -0.004	0.750	0.254	0639150
2.125	+0.007 +0.000	1.500	+0.003 -0.003	1.928	+0.000 -0.002	2.062	+0.004 -0.004	0.937	0.250	0967650
2.250	+0.007 +0.000	1.625	+0.003 -0.003	2.055	+0.000 -0.003	2.187	+0.004 -0.004	0.937	0.250	1432650
2.250	+0.007 +0.000	1.625	+0.003 -0.003	2.071	+0.000 -0.003	2.211	+0.004 -0.004	0.750	0.254	0640450
2.375	+0.007 +0.000	1.750	+0.003 -0.003	2.180	+0.000 -0.003	2.312	+0.004 -0.004	0.750	0.250	0890850
2.375	+0.007 +0.000	1.750	+0.003 -0.003	2.180	+0.000 -0.003	2.312	+0.004 -0.004	0.937	0.250	0939850
2.500	+0.007 +0.000	1.875	+0.003 -0.003	2.305	+0.000 -0.003	2.437	+0.004 -0.004	0.937	0.250	0867250
2.500	+0.007 +0.000	1.875	+0.003 -0.003	2.321	+0.000 -0.003	2.460	+0.004 -0.004	0.750	0.254	6502250
2.625	+0.007 +0.000	2.000	+0.004 -0.004	2.428	+0.000 -0.003	2.562	+0.004 -0.004	0.937	0.250	1371050

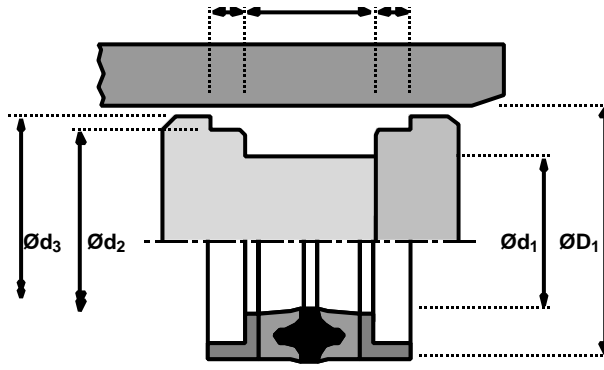
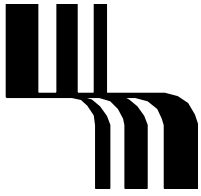

Piston seals

Hallite 58 inch

ØD ₁	TOL H11	Ød ₁	TOL js11	Ød ₂	TOL h9	Ød ₃	TOL js11	L ₁ + 0.035 + 0.025	L ₂ 0 - 0.005	PART No.
2.750	+0.007 +0.000	2.000	+0.004 -0.004	2.485	+0.000 -0.003	2.687	+0.004 -0.004	1.187	0.250	1369150
2.750	+0.007 +0.000	2.000	+0.004 -0.004	2.524	+0.000 -0.003	2.710	+0.004 -0.004	0.937	0.254	0783250
2.875	+0.007 +0.000	2.125	+0.004 -0.004	2.610	+0.000 -0.003	2.812	+0.004 -0.004	1.187	0.250	0779650
3.000	+0.007 +0.000	2.250	+0.004 -0.004	2.735	+0.000 -0.003	2.937	+0.004 -0.004	1.187	0.250	1098450
3.000	+0.007 +0.000	2.250	+0.004 -0.004	2.774	+0.000 -0.003	2.960	+0.004 -0.004	0.937	0.254	6502450
3.125	+0.007 +0.000	2.375	+0.004 -0.004	2.858	+0.000 -0.003	3.062	+0.004 -0.004	1.187	0.250	1024850
3.250	+0.009 +0.000	2.500	+0.004 -0.004	2.985	+0.000 -0.003	3.187	+0.004 -0.004	1.187	0.250	0782450
3.250	+0.009 +0.000	2.500	+0.004 -0.004	3.024	+0.000 -0.003	3.210	+0.004 -0.004	0.937	0.254	1154150
3.375	+0.009 +0.000	2.625	+0.004 -0.004	3.108	+0.000 -0.003	3.312	+0.004 -0.004	1.187	0.250	0773850
3.375	+0.009 +0.000	2.625	+0.004 -0.004	3.110	+0.000 -0.003	3.312	+0.004 -0.004	1.000	0.250	2199650
3.500	+0.009 +0.000	2.750	+0.004 -0.004	3.235	+0.000 -0.003	3.437	+0.004 -0.004	1.187	0.250	0437850
3.500	+0.009 +0.000	2.750	+0.004 -0.004	3.273	+0.000 -0.003	3.460	+0.004 -0.004	0.937	0.254	6500550
3.625	+0.009 +0.000	2.875	+0.004 -0.004	3.360	+0.000 -0.003	3.562	+0.004 -0.004	1.187	0.250	1474550
3.750	+0.009 +0.000	3.000	+0.004 -0.004	3.485	+0.000 -0.003	3.687	+0.004 -0.004	1.187	0.250	0410550
3.875	+0.009 +0.000	3.125	+0.004 -0.004	3.610	+0.000 -0.003	3.812	+0.004 -0.004	1.187	0.250	0295850
4.000	+0.009 +0.000	3.250	+0.004 -0.004	3.735	+0.000 -0.003	3.937	+0.004 -0.004	1.187	0.250	1407750
4.000	+0.009 +0.000	3.250	+0.004 -0.004	3.772	+0.000 -0.003	3.958	+0.004 -0.004	0.937	0.254	6504750
4.250	+0.009 +0.000	3.500	+0.004 -0.004	3.985	+0.000 -0.003	4.187	+0.004 -0.004	1.187	0.250	1128850
4.250	+0.009 +0.000	3.500	+0.004 -0.004	4.022	+0.000 -0.003	4.210	+0.004 -0.004	0.937	0.254	6504550
4.500	+0.009 +0.000	3.500	+0.004 -0.004	4.234	+0.000 -0.003	4.437	+0.004 -0.004	1.500	0.375	0448850
4.625	+0.009 +0.000	3.625	+0.004 -0.004	4.355	+0.000 -0.003	4.582	+0.004 -0.004	1.250	0.254	6504350
4.750	+0.010 +0.000	3.750	+0.004 -0.004	4.483	+0.000 -0.003	4.700	+0.005 -0.005	1.250	0.254	0038250
4.750	+0.010 +0.000	3.750	+0.004 -0.004	4.485	+0.000 -0.003	4.687	+0.005 -0.005	1.500	0.375	1007050

Piston seals

Hallite 58

inch

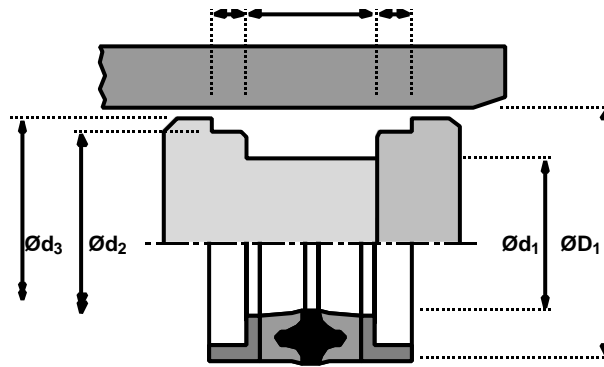
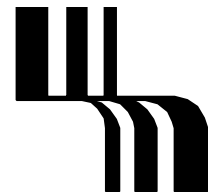

ØD ₁	TOL H11	Ød ₁	TOL js11	Ød ₂	TOL h9	Ød ₃	TOL js11	L ₁ + 0.035 + 0.025	L ₂ 0 - 0.005	PART No.
5.000	+0.010 +0.000	4.000	+0.004 -0.004	4.730	+0.000 -0.004	4.956	+0.005 -0.005	1.250	0.254	6500650
5.000	+0.010 +0.000	4.000	+0.004 -0.004	4.735	+0.000 -0.004	4.937	+0.005 -0.005	1.500	0.375	0443050
5.250	+0.010 +0.000	4.250	+0.004 -0.004	4.980	+0.000 -0.004	5.187	+0.005 -0.005	1.500	0.375	0892250
5.500	+0.010 +0.000	4.500	+0.004 -0.004	5.236	+0.000 -0.004	5.437	+0.005 -0.005	1.500	0.375	0133250
5.500	+0.010 +0.000	4.500	+0.004 -0.004	5.235	+0.000 -0.004	5.456	+0.005 -0.005	1.250	0.254	6504150
5.750	+0.010 +0.000	4.750	+0.005 -0.005	5.484	+0.000 -0.004	5.687	+0.005 -0.005	1.500	0.375	1366950
6.000	+0.010 +0.000	5.000	+0.005 -0.005	5.728	+0.000 -0.004	5.954	+0.005 -0.005	1.250	0.254	0557950
6.000	+0.010 +0.000	5.000	+0.005 -0.005	5.736	+0.000 -0.004	5.937	+0.005 -0.005	1.500	0.375	1367050
6.250	+0.010 +0.000	5.250	+0.005 -0.005	5.984	+0.000 -0.004	6.187	+0.005 -0.005	1.500	0.375	0083350
6.500	+0.010 +0.000	5.500	+0.005 -0.005	6.227	+0.000 -0.004	6.454	+0.005 -0.005	1.250	0.254	6504650
6.500	+0.010 +0.000	5.500	+0.005 -0.005	6.236	+0.000 -0.004	6.437	+0.005 -0.005	1.500	0.375	1164150
6.750	+0.010 +0.000	5.750	+0.005 -0.005	6.484	+0.000 -0.004	6.687	+0.005 -0.005	1.500	0.375	1286150
7.000	+0.010 +0.000	6.000	+0.005 -0.005	6.736	+0.000 -0.004	6.937	+0.005 -0.005	1.500	0.375	1188850
7.500	+0.010 +0.000	6.250	+0.005 -0.005	7.240	+0.000 -0.004	7.437	+0.006 -0.006	1.875	0.375	1255250
8.000	+0.011 +0.000	7.000	+0.005 -0.005	7.740	+0.000 -0.005	7.937	+0.006 -0.006	1.250	0.375	0224350
9.000	+0.011 +0.000	7.750	+0.006 -0.006	8.740	+0.000 -0.005	8.937	+0.006 -0.006	1.875	0.375	1266650
9.000	+0.011 +0.000	8.000	+0.006 -0.006	8.736	+0.000 -0.005	8.937	+0.006 -0.006	1.250	0.375	1273750
10.000	+0.013 +0.000	9.000	+0.006 -0.006	9.740	+0.000 -0.005	9.937	+0.006 -0.006	1.250	0.375	0697650