

Piston Seals

Hallite

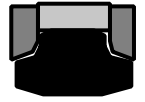

735

TECHNICAL DETAILS		METRIC	INCH
OPERATING CONDITIONS			
MAXIMUM SPEED	1.5 m/sec	4.5 ft/sec	
TEMPERATURE RANGE	-40°C +120°C	-40°F + 250°F	
MAXIMUM PRESSURE	500 bar	7500 p.s.i.	
MAXIMUM EXTRUSION GAP			
PRESSURE bar	160	250	400
MAXIMUM GAP mm	1.0	0.8	0.6
PRESSURE p.s.i.	2400	3750	6000
MAXIMUM GAP in	0.040	0.030	0.024
SURFACE ROUGHNESS			
DYNAMIC SEALING FACE $\varnothing D_1$	μmRa	μmRt	μinCLA μinRMS
STATIC SEALING FACE $\varnothing d_1$	0.1 ↔ 0.4	4 max	4 ↔ 16 5 ↔ 18
STATIC HOUSING FACES L_1	1.6 max	10 max	63 max 70 max
	3.2 max	16 max	125 max 140 max
CHAMFERS & RADII			
GROOVE SECTION S mm	7.0	7.5	11.5
MIN CHAMFER C mm	4.0	5.0	7.0
MAX FILLET RAD r_1 mm	0.8	0.8	0.8
GROOVE SECTION S in	0.187	0.240	0.365
MIN CHAMFER C in	0.160	0.200	0.250
MAX FILLET RAD r_1 in	0.016	0.016	0.035
TOLERANCES			
mm	$\varnothing D_1$	$\varnothing d_1$	L_1
	H9	+0 -0.2	+0.2 -0
in	H9	*see below	+0.01 -0
$\varnothing D_1$ in	3.000	4.500	4.500
* $\varnothing d_1$ Tol =	+0 - 0.002	+0 - 0.003	+0 - 0.004
*NB	Part numbers 710600_ and 710800_ Tol = ±0.003		

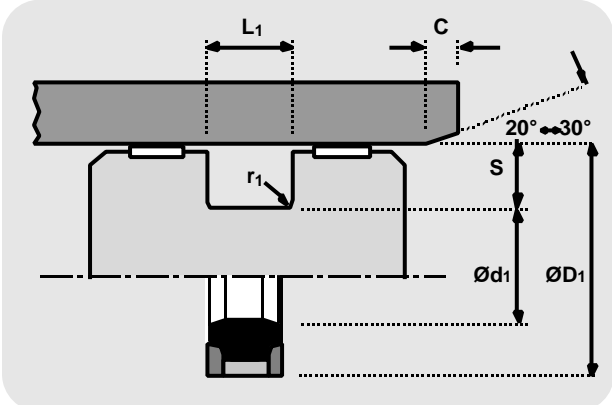

MATERIALS

Please ensure the correct part number is used for the required cap ring.

PTFE, 40% bronze
Last digit of part no. _____ 0

or

PTFE, 15% glass 5% MoS₂
Last digit of part no. _____ 1

Products suffixed † are designed to suit popular Asian housings

For information about other material options available, please contact your local Hallite Seals office.

DESIGN

Hallite's 735 is a compact double acting piston seal assembly designed for one piece pistons and is suitable for low to high pressure, medium to heavy duty applications. The assembly comprises as standard a self lubricating wear resistant bronze filled or glass / MoS₂ filled PTFE cap ring, which is loaded by a NBR energiser. Thermoplastic split anti-extrusion rings support the seal on both sides and prevent contamination of the the energiser and cap ring.

Hallite's 735 piston seal is designed to be used in a variety of equipment and is particularly suited to use in earthmoving and other off-highway equipment.

The range consists of seals to suit popular North American and Asian housings.

FEATURES

- HIGH PRESSURE
- HEAVY DUTY
- PTFE CAP RING
- COMPACT DESIGN
- LOW FRICTION
- LONG LIFE
- RANGE OF MATERIAL OPTIONS TO EXTEND SERVICE TEMPERATURE RANGE

Piston seals

Hallite 735

metric

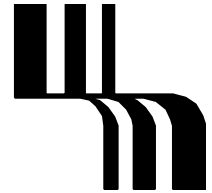
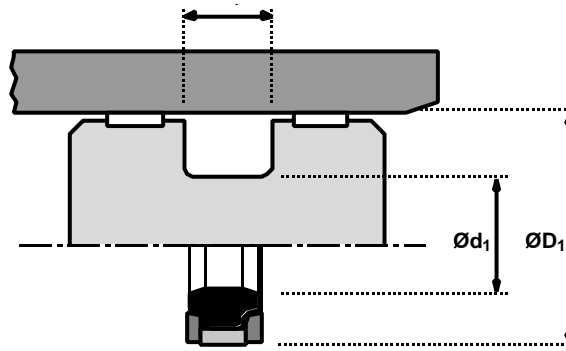

ØD_1	TOL H9	Ød_1	TOL	L_1 +0.2-0.0	PART No.
50	+0.06 +0.00	36	+0.00 -0.20	9.0	715100_†
60	+0.07 +0.00	46	+0.00 -0.20	9.0	715150_†
63	+0.07 +0.00	48	+0.00 -0.20	11.0	715200_†
65	+0.07 +0.00	50	+0.00 -0.20	11.0	715250_†
70	+0.07 +0.00	55	+0.00 -0.20	11.0	715300_†
75	+0.07 +0.00	60	+0.00 -0.20	11.0	715350_†
80	+0.07 +0.00	65	+0.00 -0.20	11.0	715400_†
85	+0.09 +0.00	70	+0.00 -0.20	11.0	715450_†
90	+0.09 +0.00	75	+0.00 -0.20	11.0	715500_†
95	+0.09 +0.00	80	+0.00 -0.20	11.0	715550_†
100	+0.09 +0.00	85	+0.00 -0.20	12.5	715600_†
105	+0.09 +0.00	90	+0.00 -0.20	12.5	715650_†
110	+0.09 +0.00	95	+0.00 -0.20	12.5	715700_†
115	+0.09 +0.00	100	+0.00 -0.20	12.5	715750_†
120	+0.09 +0.00	105	+0.00 -0.20	12.5	715800_†
125	+0.10 +0.00	102	+0.00 -0.20	16.0	715850_
130	+0.10 +0.00	107	+0.00 -0.20	16.0	715900_†
135	+0.10 +0.00	112	+0.00 -0.20	16.0	715950_†
140	+0.10 +0.00	117	+0.00 -0.20	16.0	716000_†

ØD_1	TOL H9	Ød_1	TOL	L_1 +0.2-0.0	PART No.
145	+0.10 +0.00	122	+0.00 -0.20	16.0	716050_†
150	+0.10 +0.00	127	+0.00 -0.20	16.0	716100_†
160	+0.10 +0.00	137	+0.00 -0.20	16.0	716150_†
165	+0.10 +0.00	142	+0.00 -0.20	16.0	716200_†
170	+0.10 +0.00	147	+0.00 -0.20	16.0	716250_†
175	+0.10 +0.00	152	+0.00 -0.20	16.0	716280_†
180	+0.10 +0.00	157	+0.00 -0.20	16.0	716300_†
185	+0.12 +0.00	162	+0.00 -0.20	16.0	716350_†
190	+0.12 +0.00	167	+0.00 -0.20	16.0	716400_†
200	+0.12 +0.00	177	+0.00 -0.20	16.0	716450_†
210	+0.12 +0.00	187	+0.00 -0.20	16.0	716500_†
215	+0.12 +0.00	192	+0.00 -0.20	16.0	716530_†
220	+0.12 +0.00	197	+0.00 -0.20	16.0	716550_†
225	+0.12 +0.00	202	+0.00 -0.20	16.0	716600_†
230	+0.12 +0.00	207	+0.00 -0.20	16.0	716650_†
240	+0.12 +0.00	217	+0.00 -0.20	16.0	716700_†
250	+0.12 +0.00	222	+0.00 -0.20	17.5	716750_†
260	+0.13 +0.00	232	+0.00 -0.20	17.5	716800_†
350	+0.14 +0.00	322	+0.00 -0.20	17.5	716950_†

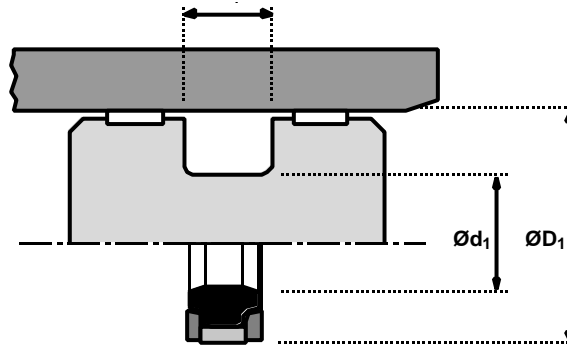
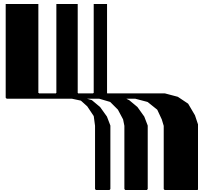

Piston seals

Hallite 735

inch

ØD ₁	TOL H9	Ød ₁	TOL	L ₁ +0.010 -0.000	PART No.
1.750	+0.002 -0.000	1.377	+0.000 -0.002	0.424	710030_
2.000	+0.002 -0.000	1.627	+0.000 -0.002	0.424	710050_
2.500	+0.002 -0.000	2.127	+0.000 -0.002	0.424	710070_
3.000	+0.003 -0.000	2.522	+0.000 -0.003	0.579	710100_
3.250	+0.003 -0.000	2.772	+0.000 -0.003	0.579	710150_
3.500	+0.003 -0.000	3.022	+0.000 -0.003	0.579	710200_
3.750	+0.003 -0.000	3.272	+0.000 -0.003	0.579	710250_
4.000	+0.003 -0.000	3.522	+0.000 -0.003	0.579	710300_
4.250	+0.003 -0.000	3.772	+0.000 -0.003	0.579	710350_
4.500	+0.003 -0.000	3.909	+0.000 -0.003	0.492	710390_
4.500	+0.003 -0.000	4.022	+0.000 -0.003	0.579	710400_
4.750	+0.004 -0.000	4.159	+0.000 -0.003	0.492	710420_
5.000	+0.004 -0.000	4.094	+0.000 -0.003	0.630	710440_
5.000	+0.004 -0.000	4.274	+0.000 -0.004	0.750	710450_
5.250	+0.004 -0.000	4.524	+0.000 -0.004	0.750	710500_
5.500	+0.004 -0.000	4.594	+0.000 -0.004	0.630	710540_
5.500	+0.004 -0.000	4.774	+0.000 -0.004	0.750	710550_
5.500	+0.004 -0.000	5.022	+0.000 -0.003	0.579	710600_
6.000	+0.004 -0.000	5.094	+0.000 -0.004	0.630	710640_
6.000	+0.004 -0.000	5.274	+0.000 -0.004	0.750	710650_
6.250	+0.004 -0.000	5.344	+0.000 -0.004	0.630	710680_
6.250	+0.004 -0.000	5.772	+0.000 -0.004	0.579	710690_
6.250	+0.004 -0.000	5.524	+0.000 -0.004	0.750	710700_
6.250	+0.004 -0.000	5.772	+0.000 -0.004	0.579	710690_

ØD ₁	TOL H9	Ød ₁	TOL	L ₁ +0.010 -0.000	PART No.
6.500	+0.004 -0.000	5.594	+0.000 -0.004	0.630	710740_
6.500	+0.004 -0.000	5.774	+0.000 -0.004	0.750	710750_
6.500	+0.004 -0.000	6.022	+0.000 -0.003	0.579	710800_
7.000	+0.004 -0.000	6.094	+0.000 -0.004	0.630	710840_
7.000	+0.004 -0.000	6.274	+0.000 -0.004	0.750	710850_
7.250	+0.005 -0.000	6.344	+0.000 -0.004	0.630	710860_
7.500	+0.005 -0.000	6.594	+0.000 -0.004	0.630	710890_
7.500	+0.005 -0.000	6.774	+0.000 -0.004	0.750	710900_
7.750	+0.005 -0.000	6.844	+0.000 -0.004	0.630	710920_
8.000	+0.005 -0.000	7.274	+0.000 -0.004	0.750	710950_
8.250	+0.005 -0.000	7.344	+0.000 -0.004	0.630	710970_
8.500	+0.005 -0.000	7.594	+0.000 -0.004	0.630	710990_
8.500	+0.005 -0.000	7.774	+0.000 -0.004	0.750	711000_
9.000	+0.005 -0.000	8.274	+0.000 -0.004	0.750	711050_
10.000	+0.005 -0.000	8.898	+0.000 -0.004	0.687	711090_
10.000	+0.005 -0.000	9.275	+0.000 -0.004	0.750	711100_
10.500	+0.005 -0.000	9.398	+0.000 -0.004	0.687	711120_
11.000	+0.005 -0.000	10.275	+0.000 -0.004	0.750	711150_
11.500	+0.005 -0.000	10.398	+0.000 -0.004	0.687	711170_
12.000	+0.005 -0.000	11.275	+0.000 -0.004	0.750	711200_
12.500	+0.005 -0.000	11.775	+0.000 -0.004	0.750	7112201
14.000	+0.005 -0.000	12.898	+0.000 -0.004	0.687	711270_
15.000	+0.005 -0.000	14.275	+0.000 -0.004	0.750	711300_

Notes

