

Piston seals

Hallite

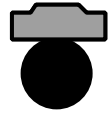

754

TECHNICAL DETAILS		METRIC	INCH		
OPERATING CONDITIONS					
MAXIMUM SPEED		1.0 m/sec	3.0 ft/sec		
TEMPERATURE RANGE		-40°C + 110°C	-40°F + 230°F		
MAXIMUM PRESSURE		350 bar	5000 p.s.i.		
MAXIMUM EXTRUSION GAP					
PRESSURE bar		100	160	250	350
MAXIMUM GAP (S>7) mm		1.0	0.8	0.6	0.4
MAXIMUM GAP (S<7) mm		0.8	0.6	0.5	0.3
PRESSURE p.s.i.		1500	2400	3750	5000
SURFACE ROUGHNESS					
DYNAMIC SEALING FACE $\varnothing D_1$		μmRa 0.1 ↔ 0.4	μmRt 4 max	μinCLA 4 ↔ 16	μinRMS 5 ↔ 18
STATIC SEALING FACE $\varnothing d_1$		1.6 max	10 max	63 max	70 max
STATIC HOUSING FACES L_1		3.2 max	16 max	125 max	140 max
CHAMFERS & RADII					
GROOVE SECTION S mm		3.75	5.50	7.50	10.50
MIN CHAMFER C mm		2.00	2.50	5.00	5.00
MAX FILLET RAD r_1 mm		0.40	0.80	1.20	1.60
TOLERANCES					
		$\varnothing D_1$	$\varnothing d_1$	L_1	
	mm	H9	f8	+0.2 -0	

Figures show the maximum permissible gap all on one side using the minimum clearance \varnothing and maximum bore \varnothing

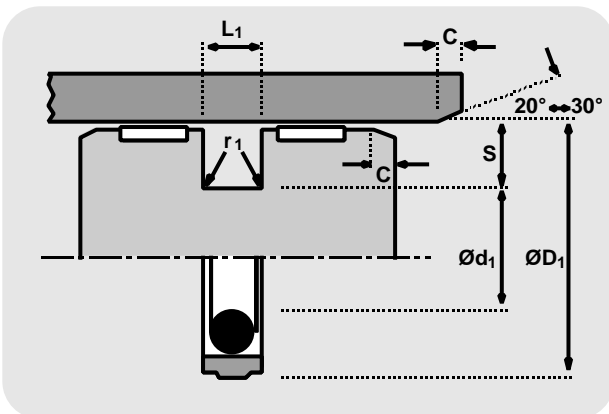

MATERIAL OPTIONS

Face material

Polyester elastomer - standard (Red 55D)
Last digit of part no. _____ 0

Lubricated polyester elastomer
Last digit of part no. _____ 2

Hydrolysis stabilised polyester elastomer (Red 72D)
Last digit of part no. _____ 3

Hythane 181 - *A limited number of sizes are available in this material option*
Last digit of part no. _____ 4

For full details and availability please contact your local Hallite sales office. Technical details shown are for standard Red 55D polyester elastomer.

DESIGN

The Hallite 754 double acting piston seal is a compact low friction seal for light to medium duty hydraulic cylinders. As standard, it comprises a tough, wear resistant thermoplastic elastomer face, (see left for face material options) which is pre-loaded by an O ring. The housing width allows a narrow width piston to be used, but it is recommended that an adequate bearing is mounted on one or both sides of the seal. Housing dimensions for use with Hallite 87 and 506 bearing strip are given in the installation details. For further details of bearing strip grooves, please refer to the appropriate data sheets.

NB: Part numbers suffixed by "‡" indicate housing sizes to meet ISO 7425-1.

FEATURES

- LOW BREAK-OUT AND OPERATING FRICTION LEVELS.
- RAPID RECOVERY OF FACE AFTER ASSEMBLY. UNLIKE COMMON PTFE FACES, NO RE-SIZING IS REQUIRED.
- MORE TOLERANT TO CONTAMINATION THAN COMMON PTFE EQUIVALENTS.
- EXCELLENT POSITION HOLDING CHARACTERISTICS UNDER LOAD
- COMPATIBLE WITH MOST HYDRAULIC FLUIDS.
- EXCELLENT WEAR RESISTANCE.
- OPERATES ON A WIDE RANGE OF SURFACE FINISHES.
- IDEAL FOR USE WITH HALLITE 506 OR 87 BEARING STRIP.
- ISO 7425 HOUSINGS.

Piston seals

Hallite 754

metric

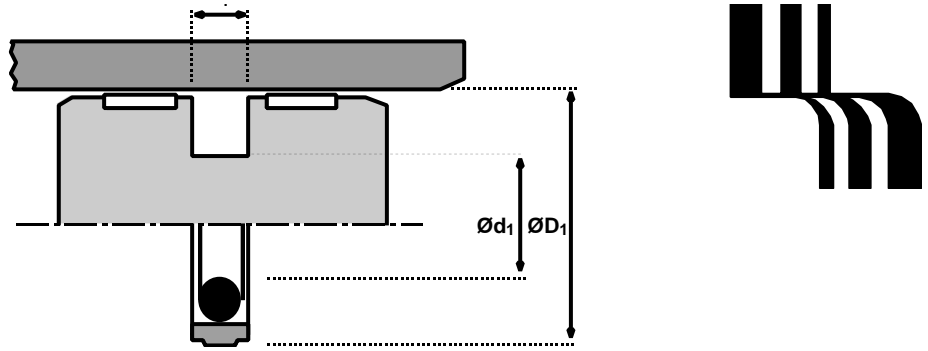

ØD ₁	TOL H9	Ød ₁	TOL f8	L ₁ + 0.2 - 0	PART No.
15	+0.04 +0.00	7.5	-0.01 -0.04	3.20	444641_
16	+0.04 +0.00	8.5	-0.01 -0.04	3.20	440061_‡
20	+0.05 +0.00	12.5	-0.02 -0.04	3.20	436231_‡
25	+0.05 +0.00	17.5	-0.02 -0.04	3.20	433961_‡
30	+0.05 +0.00	22.5	-0.02 -0.05	3.20	433971_
32	+0.06 +0.00	24.5	-0.02 -0.05	3.20	433981_‡
35	+0.06 +0.00	27.5	-0.02 -0.05	3.20	435241_
38.1	+0.06 +0.00	27.1	-0.02 -0.05	4.20	443231_
38.1	+0.06 +0.00	30.6	-0.03 -0.06	3.20	442871_
40	+0.06 +0.00	29.0	-0.02 -0.05	4.20	433921_‡
45	+0.06 +0.00	34.0	-0.03 -0.06	4.20	434231_
50	+0.06 +0.00	34.5	-0.03 -0.06	6.30	442741_‡
50	+0.06 +0.00	39.0	-0.03 -0.06	4.20	432711_‡
50.8	+0.06 +0.00	39.8	-0.03 -0.06	4.20	432711_
55	+0.07 +0.00	39.5	-0.03 -0.06	6.30	435561_
55	+0.07 +0.00	44.0	-0.03 -0.06	4.20	446551_
60	+0.07 +0.00	44.5	-0.03 -0.06	6.3	439071_
60	+0.07 +0.00	49.0	-0.03 -0.06	4.20	432701_
63	+0.07 +0.00	47.5	-0.03 -0.08	6.30	443111_‡
63	+0.07 +0.00	50.0	-0.03 -0.08	6.30	447231_
63	+0.07 +0.00	52.0	-0.03 -0.08	4.20	432691_‡
63.5	+0.07 +0.00	52.5	-0.03 -0.08	4.20	432691_
65	+0.07 +0.00	49.5	-0.03 -0.06	6.30	436201_

ØD ₁	TOL H9	Ød ₁	TOL f8	L ₁ + 0.2 - 0	PART No.
65	+0.07 +0.00	52.0	-0.03 -0.08	6.30	438491_
65	+0.07 +0.00	54.0	-0.03 -0.08	4.20	435301_
70	+0.07 +0.00	57.0	-0.03 -0.08	6.30	439081_
70	+0.07 +0.00	59.0	-0.03 -0.08	4.20	432681_
75	+0.07 +0.00	59.5	-0.03 -0.08	6.30	470491_
75	+0.07 +0.00	59.5	-0.03 -0.08	6.30	4621300
75	+0.07 +0.00	59.5	-0.03 -0.08	6.30	4631600
75	+0.07 +0.00	64.0	-0.03 -0.08	4.20	433991_
75	+0.07 +0.00	68.0	-0.03 -0.08	6.30	4631700
80	+0.07 +0.00	64.5	-0.03 -0.08	6.30	427091_‡
82.5	+0.09 +0.00	67.0	-0.03 -0.08	6.30	442881_
85	+0.09 +0.00	69.5	-0.03 -0.08	6.30	456401_
90	+0.09 +0.00	74.5	-0.03 -0.08	6.30	437271_
95	+0.09 +0.00	79.5	-0.03 -0.08	6.30	456951_
100	+0.09 +0.00	84.5	-0.04 -0.09	6.30	433931_‡
101.6	+0.09 +0.00	86.1	-0.04 -0.09	6.30	442891_
105	+0.09 +0.00	89.5	-0.04 -0.09	6.30	437251_
110	+0.09 +0.00	94.5	-0.04 -0.09	6.30	441931_
115	+0.09 +0.00	99.5	-0.04 -0.09	6.30	435581_
120	+0.10 +0.00	99.0	-0.04 -0.09	8.10	453501_
120	+0.10 +0.00	104.5	-0.04 -0.09	6.30	446541_
125	+0.10 +0.00	104.0	-0.04 -0.09	8.10	437651_‡
125	+0.10 +0.00	109.5	-0.04 -0.09	6.30	434001_‡

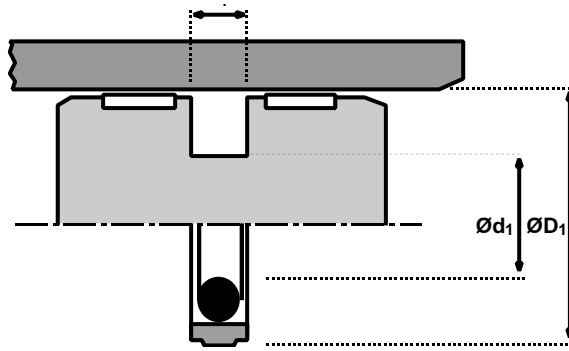
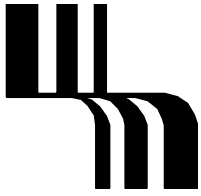

Piston seals
Hallite
754
 metric

$\varnothing D_1$	TOL H9	$\varnothing d_1$	TOL f8	L_1 + 0.2 - 0	PART No.
127	+0.10 +0.00	111.5	-0.04 -0.09	6.30	442901_
130	+0.10 +0.00	109.0	-0.04 -0.09	8.10	440241_
130	+0.10 +0.00	114.5	-0.04 -0.09	6.30	434221_
135	+0.10 +0.00	114.0	-0.04 -0.09	8.10	453511_
140	+0.10 +0.00	119.0	-0.04 -0.09	8.10	434011_
140	+0.10 +0.00	124.5	-0.04 -0.11	6.30	449941_
150	+0.10 +0.00	129.0	-0.04 -0.11	8.10	439691_
160	+0.10 +0.00	139.0	-0.04 -0.11	8.10	434021_‡
165	+0.10 +0.00	144.0	-0.04 -0.11	8.10	445221_
170	+0.10 +0.00	149.0	-0.04 -0.11	8.10	434031_

$\varnothing D_1$	TOL H9	$\varnothing d_1$	TOL f8	L_1 + 0.2 - 0	PART No.
180	+0.10 +0.00	159.0	-0.04 -0.11	8.10	434041_
190	+0.12 +0.00	169.0	-0.04 -0.11	8.10	434241_
200	+0.12 +0.00	179.0	-0.04 -0.11	8.10	434051_‡
210	+0.12 +0.00	189.0	-0.05 -0.12	8.10	435151_
225	+0.12 +0.00	204.0	-0.05 -0.12	8.10	451281_
240	+0.12 +0.00	219.0	-0.05 -0.12	8.10	455361_
250	+0.12 +0.00	229.0	-0.05 -0.12	8.10	439371_‡
300	+0.13 +0.00	279.0	-0.06 -0.14	8.10	457281_

Notes

