

Piston seals

Hallite

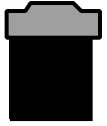

592

TECHNICAL DETAILS

METRIC

INCH

OPERATING CONDITIONS

MAXIMUM SPEED
TEMPERATURE RANGE
MAXIMUM PRESSURE

1.0 m/sec
-40°C + 110°C
350 bar

3.0 ft/sec
-40°F + 230°F
5000 p.s.i.

MAXIMUM EXTRUSION GAP

PRESSURE bar
PRESSURE p.s.i.
MAXIMUM GAP (S>0.280) in
MAXIMUM GAP (S<0.280) in

Figures show the maximum permissible gap all on one side using the minimum clearance \emptyset and maximum bore \emptyset

100	160	250	350
1500	2400	3750	5000
0.030	0.025	0.020	0.010
0.025	0.020	0.015	0.005

SURFACE ROUGHNESS

DYNAMIC SEALING FACE $\emptyset D_1$
STATIC SEALING FACE $\emptyset d_1$
STATIC HOUSING FACES L_1

μmRa	μmRt	μinCLA	μinRMS
0.1 \leftrightarrow 0.4	4 max	4 \leftrightarrow 16	5 \leftrightarrow 18
1.6 max	10 max	63 max	70 max
3.2 max	16 max	125 max	140 max

CHAMFERS & RADII

GROOVE SECTION S in
MIN CHAMFER C in
MAX FILLET RAD r_1 in

0.154	0.269	0.373	0.431
0.100	0.150	0.200	0.200
0.016	0.016	0.016	0.016

TOLERANCES

in
 L_1 in
 L_1

$\emptyset D_1$	$\emptyset d_1$
H9	js10
= 0.129	= 0.283
± 0.002	± 0.003
	> 0.283
	± 0.004

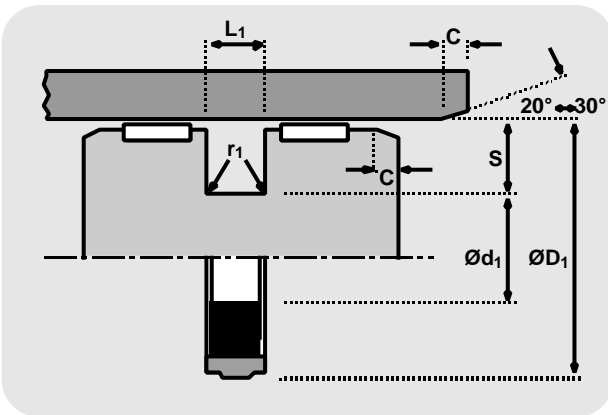

MATERIALS

Standard face material:
Polyester elastomer - (red 55D)
Last digit of part no. ----- 0

Face material options:
Hydrolysis stabilised polyester elastomer (Grey 55D)
Last digit of part no. ----- 1

Lubricated polyester elastomer
Last digit of part no. ----- 2

Hydrolysis stabilised polyester elastomer (Red 72D)
Last digit of part no. ----- 3

Hythane 181 - *A limited number of sizes are available in this material option*
Last digit of part no. ----- 4

Technical details shown are for standard Red 55D polyester elastomer.

DESIGN

The Hallite 755 seal is a compact, low friction seal for light to medium duty hydraulic cylinders. Designed originally to the North American housing standards, the 755 is an inch version of Hallite's 754. It comprises of a very tough elastomeric face (see material options) which is pre-loaded by a square section ring (as North American convention). Please note part numbers marked * are supplied with an O ring energiser.

It is recommended that an adequate bearing is mounted on both sides of the seal. See Hallite 506 bearing strip.

For full details and availability please contact your local Hallite sales office.

FEATURES

- LOW BREAK-OUT AND OPERATING FRICTION LEVELS.
- RAPID RECOVERY OF FACE AFTER ASSEMBLY. UNLIKE COMMON PTFE FACES, NO RE-SIZING IS REQUIRED.
- MORE TOLERANT TO DIRT AND CONTAMINATION THAN COMMON PTFE EQUIVALENTS.
- EXCELLENT POSITION HOLDING CHARACTERISTICS UNDER LOAD
- COMPATIBLE WITH MOST HYDRAULIC FLUIDS.
- EXCELLENT WEAR RESISTANCE.
- OPERATES ON A WIDE RANGE OF SURFACE FINISHES.
- IDEAL FOR USE WITH HALLITE'S 506 BEARING STRIP

Piston seals

Hallite 755

inch

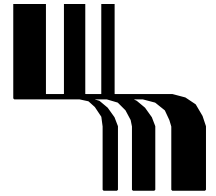
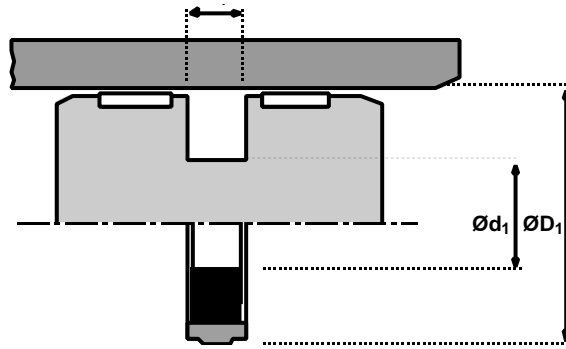

ØD ₁	TOL H9	Ød ₁	TOL js10	L ₁	TOL	PART No.
1.000	+0.002 +0.000	0.691	+0.001 -0.001	0.129	+0.002 -0.002	891000_
1.250	+0.002 +0.000	0.941	+0.002 -0.002	0.129	+0.002 -0.002	891010_
1.500	+0.002 +0.000	1.191	+0.002 -0.002	0.129	+0.002 -0.002	891020_
1.750	+0.002 +0.000	1.441	+0.002 -0.002	0.129	+0.002 -0.002	891030_
2.000	+0.003 +0.000	1.462	+0.002 -0.002	0.283	+0.003 -0.003	455352_
2.000	+0.003 +0.000	1.606	+0.002 -0.002	0.129	+0.002 -0.002	891310_*
2.000	+0.003 +0.000	1.691	+0.002 -0.002	0.129	+0.002 -0.002	891040_
2.250	+0.003 +0.000	1.941	+0.002 -0.002	0.129	+0.002 -0.002	891050_
2.500	+0.003 +0.000	1.962	+0.002 -0.002	0.283	+0.003 -0.003	449002_
2.500	+0.003 +0.000	2.106	+0.002 -0.002	0.129	+0.002 -0.002	443931_*
2.500	+0.003 +0.000	2.191	+0.002 -0.002	0.129	+0.002 -0.002	891060_
2.750	+0.003 +0.000	2.441	+0.002 -0.002	0.129	+0.002 -0.002	891070_
3.000	+0.003 +0.000	2.462	+0.002 -0.002	0.283	+0.003 -0.003	891080_
3.250	+0.003 +0.000	2.712	+0.002 -0.002	0.283	+0.003 -0.003	891090_
3.500	+0.003 +0.000	2.962	+0.002 -0.002	0.283	+0.003 -0.003	891100_
3.750	+0.003 +0.000	3.212	+0.002 -0.002	0.283	+0.003 -0.003	891110_
4.000	+0.003 +0.000	3.462	+0.002 -0.002	0.283	+0.003 -0.003	891120_
4.250	+0.003 +0.000	3.712	+0.002 -0.002	0.283	+0.003 -0.003	891130_
4.500	+0.003 +0.000	3.962	+0.002 -0.002	0.283	+0.003 -0.003	891140_

ØD ₁	TOL H9	Ød ₁	TOL js10	L ₁	TOL	PART No.
4.750	+0.004 +0.000	4.212	+0.002 -0.002	0.283	+0.003 -0.003	891150_
5.000	+0.004 +0.000	4.462	+0.002 -0.002	0.283	+0.003 -0.003	891160_
5.250	+0.004 +0.000	4.504	+0.002 -0.002	0.378	+0.004 -0.004	891170_
5.500	+0.004 +0.000	4.754	+0.003 -0.003	0.378	+0.004 -0.004	891180_
5.750	+0.004 +0.000	5.004	+0.003 -0.003	0.378	+0.004 -0.004	891320_
6.000	+0.004 +0.000	5.254	+0.003 -0.003	0.378	+0.004 -0.004	891190_
6.250	+0.004 +0.000	5.504	+0.003 -0.003	0.378	+0.004 -0.004	891200_
6.500	+0.004 +0.000	5.754	+0.003 -0.003	0.378	+0.004 -0.004	891210_
7.000	+0.004 +0.000	6.250	+0.003 -0.003	0.312	+0.004 -0.004	439481_*
7.000	+0.004 +0.000	6.254	+0.003 -0.003	0.378	+0.004 -0.004	891220_
7.250	+0.005 +0.000	6.504	+0.003 -0.003	0.378	+0.004 -0.004	891230_
7.500	+0.005 +0.000	6.754	+0.003 -0.003	0.378	+0.004 -0.004	891240_
8.000	+0.005 +0.000	7.254	+0.003 -0.003	0.378	+0.004 -0.004	891250_
8.437	+0.005 +0.000	7.691	+0.003 -0.003	0.378	+0.004 -0.004	891300_
8.500	+0.005 +0.000	7.754	+0.003 -0.003	0.378	+0.004 -0.004	891260_
9.000	+0.005 +0.000	8.137	+0.003 -0.003	0.378	+0.004 -0.004	891270_
9.500	+0.005 +0.000	8.637	+0.003 -0.003	0.378	+0.004 -0.004	891280_
10.000	+0.005 +0.000	9.137	+0.003 -0.003	0.378	+0.004 -0.004	891290_

* Supplied with an O ring energiser.