

Piston Seals

Hallite



072

TECHNICAL DETAILS

METRIC

INCH

OPERATING CONDITIONS

MAXIMUM SPEED
TEMPERATURE RANGE
MAXIMUM PRESSURE

1.0 m/sec
-40°C + 110°C
350 bar

3.0 ft/sec
-40°F + 230°F
5000 p.s.i.

MAXIMUM EXTRUSION GAP

PRESSURE bar
PRESSURE p.s.i.
MAXIMUM GAP in

Figures show the maximum permissible gap all on one side using the minimum clearance \emptyset and maximum bore \emptyset

100	160	250	350
1500	2400	3750	5000
0.030	0.025	0.020	0.010

SURFACE ROUGHNESS

DYNAMIC SEALING FACE $\emptyset D_1$
STATIC SEALING FACE $\emptyset d_1$
STATIC HOUSING FACES L_1

μmRa	μmRt	μinCLA	μinRMS
0.1 ↔ 0.4	4 max	4 ↔ 16	5 ↔ 18
1.6 max	10 max	63 max	70 max
3.2 max	16 max	125 max	140 max

CHAMFERS & RADII

GROOVE SECTION S in
MIN CHAMFER C in
MAX FILLET RAD r_1 in

0.125	0.187	0.250
0.100	0.150	0.200
0.016	0.016	0.016

TOLERANCE

in

$\emptyset D_1$	$\emptyset d_1$	$\emptyset d_2$	L_1
+0.002 -0	+0 -0.002	+0 -0.001	+0.005 -0

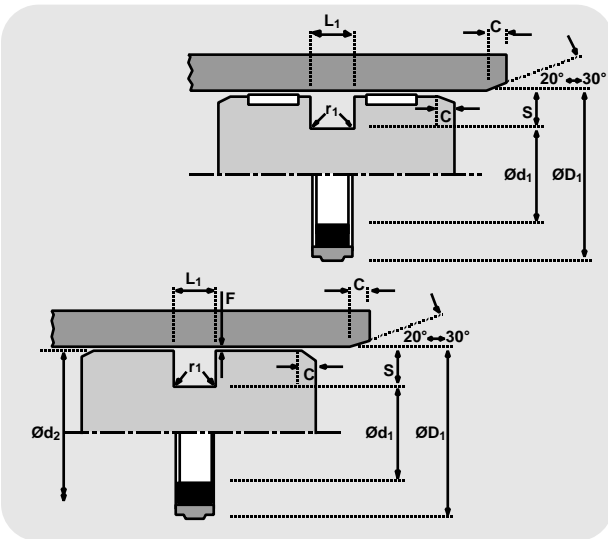

DESIGN

The Hallite 770 seal is a double acting compact, low friction seal for light to medium duty hydraulic cylinders. It has been designed to fit standard inch O ring housings. It comprises a tough self lubricated elastomeric face which is pre-loaded by a rectangular cross-section expander. It can be used on SG iron pistons or on a piston where there is an adequate remote bearing (see Hallite 506 and 533 bearings).

The standard material is only suitable for hydraulic mineral oil applications. Other material options are available for water based (HFA and HFB) fluids and synthetic esters (HEES). In certain sizes a Hythane face material option is available, particularly for intermittent single acting applications.

For full details and availability please contact your local Hallite Sales office.

MATERIAL OPTIONS

Standard face material: (Brown 55D)

Lubricated polyester elastomer

Last digit of part no. ----- 2

Face material options:

Polyester elastomer (Red 55D)

Last digit of part no. ----- 0

Hydrolysis stabilised polyester elastomer (Grey 55D)

Last digit of part no. ----- 1

Hydrolysis stabilised polyester elastomer (Red 72D)

Last digit of part no. ----- 3

Hythane 181 - *A limited number of sizes are available in this material option*

Last digit of part no. ----- 4

Technical details shown are for standard Brown 55D lubricated polyester elastomer.

FEATURES

- LOW BREAK-OUT AND OPERATING FRICTION LEVELS.
- RAPID RECOVERY OF FACE AFTER ASSEMBLY. UNLIKE COMMON PTFE FACES, NO RE-SIZING IS REQUIRED.
- MORE TOLERANT TO DIRT AND CONTAMINATION THAN COMMON PTFE EQUIVALENTS.
- EXCELLENT WEAR RESISTANCE.
- OPERATES ON A WIDE RANGE OF SURFACE FINISHES.
- IDEAL FOR USE WITH HALLITE HALLITE 506 OR 533 GFN WEAR RINGS

Piston seals

Hallite 770

inch

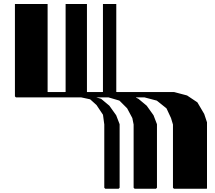
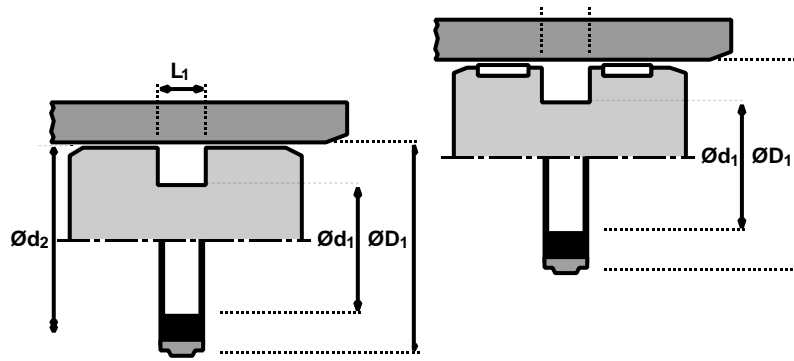

ØD ₁	TOL	Ød ₁	TOL	Ød ₂	TOL	L ₁	TOL	PART No.
1.250	+0.002 -0.000	1.008	+0.000 -0.002	1.247	+0.000 -0.001	0.187	+0.005 -0.000	455441_
2.000	+0.002 -0.000	1.630	+0.000 -0.002	1.997	+0.000 -0.001	0.281	+0.005 -0.000	455351_
2.500	+0.002 -0.000	2.130	+0.000 -0.002	2.497	+0.000 -0.001	0.281	+0.005 -0.000	449001_
3.000	+0.002 -0.000	2.630	+0.000 -0.002	2.997	+0.000 -0.001	0.281	+0.005 -0.000	434941_
3.250	+0.002 -0.000	2.880	+0.000 -0.002	3.247	+0.000 -0.001	0.281	+0.005 -0.000	434951_
3.500	+0.002 -0.000	3.130	+0.000 -0.002	3.497	+0.000 -0.001	0.281	+0.005 -0.000	434961_
3.750	+0.002 -0.000	3.380	+0.000 -0.002	3.747	+0.000 -0.001	0.281	+0.005 -0.000	434971_
4.000	+0.002 -0.000	3.630	+0.000 -0.002	3.997	+0.000 -0.001	0.281	+0.005 -0.000	434981_
4.250	+0.002 -0.000	3.880	+0.000 -0.002	4.247	+0.000 -0.001	0.281	+0.005 -0.000	434991_
4.500	+0.002 -0.000	4.130	+0.000 -0.002	4.497	+0.000 -0.001	0.281	+0.005 -0.000	435001_
4.750	+0.002 -0.000	4.380	+0.000 -0.002	4.747	+0.000 -0.001	0.281	+0.005 -0.000	435011_
5.000	+0.002 -0.000	4.630	+0.000 -0.002	4.997	+0.000 -0.001	0.281	+0.005 -0.000	435021_